

**Extremely Low Frequency Global Alert System: A  
Conceptual Design Approach  
To Extremely Low Frequency  
Subsurface Wave Propagation**

By  
Julian Parker

A MASTER OF ENGINEERING REPORT

Submitted to the College of Engineering at  
Texas Tech University  
Partial Fulfillment of  
The Requirements for the  
Degree of

MASTERS OF SYSTEMS ENGINEERING

Approved

---

Dr. J. Borrelli

---

Dr. A. Ertas

---

Dr. M.M. Tanik

---

Dr. T. T. Maxwell

October 12, 2002

## **ABSTRACT**

The concept of transmitting and receiving extremely low frequency (ELF) digital information beneath and earth's surface serves another means secure and initial early warning (IEW) communications. ELF subsurface wave propagation follows the earth's resistivity (earth electromagnetic field), instead of free space. This prevents the isolation and exploitation of the ELF signal from potential threats. The earth's resistivity and the earth's permeability confine the ELF subsurface transmissions to the earth's surface and below. The ELF subsurface communication is covert, propagates through the earth's surface and bodies of water and is unsusceptible to electromagnetic pulse (EMP).

## ACKNOWLEDGEMENTS

I wish to express my appreciation and thanks to Dr. Atila Ertas for his support and encouragement throughout this master's program. Despite the accelerated curriculum, the knowledge and the technical skills obtained the master's program was a viable asset to my professional development and career progression. I would also like to thank Dr. M. M. Tanik for the encouragement and advice during my master's report development. Furthermore, thanks go to Dr. T. T. Maxwell, who gave me a broader understanding about Thermodynamics and Heat transfer. These principles I learned are used routinely in the workplace.

I would like to express thanks to my supervisor, Dr. Jim Hinderer, from Raytheon in Richardson, who provided the recommendation, which precluded in my selection into Raytheon's Advanced Study Program for enrollment into the Texas Tech graduate program. I am also grateful for his technical guidance, patience, and concern during the program.

I would like to thank my mother, father, brother, and sister and for giving me the confidence and moral support to succeed and prosper.

Finally, I would like to thank my wife Valerie and my two boys (Julian and Julius) for their unconditional love and forbearance throughout the academic master's process. I dedicate this report to her. She endured many last nights, missed weekends, and being

alone with the children. Without her support, I would not have been able to achieve this plateau in higher education.

## **DISCLAIMER**

This master's report is to be considered a conceptual design approach to extremely low frequency subsurface wave propagation. The Extremely Low Frequency Global Alert System (EGAS) is used as prototype design to show proof of concept. The technical content expressed in this report are strictly those of the author are not necessarily those of Raytheon, Texas Tech University, or any U. S. Government agency.

## TABLE OF CONTENTS

1. INTRODUCTION.....	1
2. LITERATURE OVERVIEW.....	3
2.1 Background.....	3
2.2 History.....	4
3. EGAS SYSTEM DEVELOPMENT.....	8
3.1 System Engineering Overview.....	8
3.1.1. Project Planning.....	12
3.1.2. Organizational Structure.....	13
3.1.3. Reporting and Control.....	14
3.1.4. IPDS Reporting and Control Diagrams.....	16
3.1.5. Key Events.....	25
3.2 Technical Approach.....	28
3.2.1. E-Field Calculations.....	30
3.2.2. Results of E-Field Calculations and Analysis.....	33
3.3 Design Considerations.....	34
3.3.1. Assumptions.....	34
3.3.2. Design Constraints.....	36
3.4 EGAS System Requirements Development.....	39
3.5 Engineering Development Life Cycle.....	43
4. ELF GLOBAL ALERT SYSTEM DESCRIPTION.....	52
4.1 ELF Transmitter System.....	55
4.2 ELF Receiver System.....	59
4.2.1. The ELF Receiver Subsystem Description.....	61
4.3 EGAS Transmit and Receive Antennas.....	65
4.4 EGAS Control System.....	66
4.5 EGAS Design Features.....	69
4.6 EGAS Engineering Development.....	70
4.7 Development Costs.....	71
5. CONCLUSION.....	73
6. ACRONYMS.....	76
7. References:.....	79

## LIST OF FIGURES

Figure 3.1-1 System Engineering Design Process.....	11
Figure 3.1.2-1 Typical Organizational Structure.....	14
Figure 3.1.3-1 Reporting and Control Flow Decision Flow Diagram.....	16
Figure 3.1.4.1-1 Project Start-Up Reporting and Control Flow Diagram.....	18
Figure 3.1.4.2-1 System Requirements Review Reporting & Control Flow Diagram....	19
Figure 3.1.5.3-1 System Design Review Reporting and Control Flow Diagram.....	20
Figure 3.1.4.4-1 Preliminary Design Review Reporting and Control Flow Diagram.....	21
Figure 3.1.4.5-1 Critical Design Review Reporting and Control Flow Diagram.....	22
Figure 3.1.5.6-1 Test Readiness Review Reporting and Control Flow Diagram.....	23
Figure 3.1.4.7-1 Functional Configuration Audit Reporting and Control Flow Dgm.....	24
Figure 3.1.4.8-1 Physical Configuration Audit Reporting and Control Flow Dgm.....	25
Figure 3.3.1–1 Geological Map of Texas.....	35
Figure 3.4-2 EGAS Physical Block Diagram.....	40
Figure 3.5-1 EGAS Integrated Master Plan.....	45
Figure 3.5-2 EGAS Integrated Master Schedule.....	47
Figure 3.5-3 IPT Structure.....	48
Figure 3.5-1 Raytheon’s IPDS Process.....	51
Figure 4.0-1 ELF Global Alert System (EGAS).....	53
Figure 4.0-2 Layers of the Earth.....	54
Figure 4.1-1 ELF Transmitter System.....	56
Figure 4.2-1 ELF Receiver System.....	61
Figure 4.3-1 EGAS Transmit and Receive Antennas.....	66
Figure 4.4-1 EGAS Control System.....	67
Figure 4.4-2 Tunable Bi-Directional Steering Display.....	69

**LIST OF TABLES**

Table 3.1.6-1 IMP Event Dictionary.....	26
Table 3.2.3-1 EGAS E-Field Propagation Characteristics Results.....	34
Table 3.3.1-2 Conductivities of the Earth .....	36
Table 3.4-3 EGAS System Requirements.....	41



# CHAPTER I

## 1. INTRODUCTION

As the result of the terrorists acts conducted on 11 Sep 01, which destroyed the World Trade Center (Twin Towers) in New York City and damaged the Pentagon in Washington, DC, our national security is at a all time high. The President, by executive order, created the Office of Homeland Security. This office is responsible for coordinating national strategy to strengthen protections against terrorist attacks in the United States. The government has asked industry to come up with ideas in the fight against terrorism. Because of the heightened security posture, the “War Against Terrorism” and the campaign in Afghanistan, there is a need to develop a secure, survivable global system to communicate with key military elements and national systems in order to provide early warnings and threat status.

In response to the Homeland Security initiative, a concept was introduced to develop extremely low frequency (ELF) subsurface communication system prototype known as the Extreme Low Frequency Global Alert System (EGAS). The purpose of this design effort is to show a proof of concept of ELF two-way subsurface communication within a six-month time frame. The overall intent of this engineering development model (EDM) is to establish an ELF subsurface communication system. These systems can be strategically positioned around the world to establish a worldwide grid, which could provide timely intelligence and threat information for US forces and government agencies. The use of the ELF spectrum was selected due its the long range propagation properties. ELF radio waves penetrate deeply beneath the surface of the earth and

interact with the geologic structure of the earth. This ELF wave propagation and its interaction with earth materials will allow these waves to be used for sub-surface communications. This type of communication does not require encryption and won't be susceptible to electromagnetic pulse (EMP) or atomic destruction.

## CHAPTER II

### 2. LITERATURE OVERVIEW

#### 2.1 Background

Extremely Low Frequencies (ELF) transmissions are electromagnetic waves primarily used for naval strategic communications. ELF communications systems exercise the principles in physics, where the attenuation of radio signals (electromagnetic waves) from seawater increases with the frequency of the signal. In general, the frequency of ELF waves range from 3 Hz to 3000 Hz. One of the great difficulties associated with the use of ELF for communication purposes, is the generation of a useful signal. The physical size of an antenna that can produce a useable signal with reasonable efficiency is inversely proportional to the frequency. ELF transmissions are very slow, due to its narrow bandwidth, which affect the data rate of information. Slow Continuous Wave (Morse Code) or phase shift-keying (PSK) modulation is basically all that is feasible. This particular range is important to the US Navy because of its capability in providing a communication system for submerged submarines during covert operations. In addition, the seawater's high electrical conductivity prevents the detection of submarines and it's communication with the world above, which uses normal radio transmissions. The lower the frequency of the ELF transmissions, the deeper the signal travels in seawater, which decreases the chances of submarines being detected by enemies. The result is that ELF waves penetrate seawater to depths of hundreds of feet, permitting communications with submarines while maintaining stealth. These penetration characteristics are also applicable to earth or lossy media.

## 2.2 History

In the late 1950's, the US Navy began to investigate the use of ELF electric and magnetic fields (EMF) to communicate with submerged submarines. The EMF's produced by the ELF communication system is modulated between 72 Hz and 80 Hz to produce a binary-coded signal (1 or 0) that is transmitted to submarines. In 1969, the US Navy completed an experimental ELF communication facility known as the Naval Radio transmitting Facility (NTRF) in the Chequamegon National Forest near Clam Lake, Wisconsin. For more than a decade the NTRF operated intermittently and became fully operational in 1989. There was some concern that the ELF EMFs may be harmful to the human populace and the ecological environment. As the result of this issue, federal evaluations and trade studies were conducted on the effects of ELF electric and magnetic fields levels of all the Navy's ELF communication systems to the population and the environment. The final reports concluded that the magnetic fields and the induced electrical currents are too low and pose no risk to the environment. There are several other ELF projects proposed or developed through the course of history, which attributed to the proposed EGAS Prototype design.

- a. Ground Wave Emergency Network (GWEN) - In 1980, the Ground Wave Emergency Network (GWEN) was developed and implemented to provide survivable connectivity to designated bomber and tanker bases. The GWEN is was designed as an ultra-high powered very low frequency (VLF) [150-185 kHz] network intended to survive massive broadband destructive interference produced by nuclear electromagnetic pulse EMP, and recover quickly from the changes imposed on radio

wave propagation by EMP-ion damage to the upper atmosphere. The GWEN is a network of low frequency radio towers whose purpose is to send release messages to U.S. strategic forces at the beginning of and during a nuclear conflict. The network consists of a master (transmit/receive) station and over 200 receive-only stations and relay nodes deployed at strategic locations to obtain 360° coverage.

Based on the GWEN's architectural design and the heightened security posture, the concept of extremely low frequency subsurface wave propagation known as "EGAS" was introduced as a prototype design. The deployment of the EGAS is similar to the Ground Wave Emergency Network (GWEN). The overall intent is to strategically position a number of EGAS within a worldwide grid to provide 360° worldwide coverage. These systems will transmit and receive binary coded information, which contain current events, nuclear and chemical threats, early warning indicators, and threat control status for US strategic forces and government agencies. This information will be used to react quickly and in real-time against the threat, terrorist acts, domestic and international incidents, and to depict current threat and defense security posture.

- b. Project Sanguine - In 1977, the US Navy introduced developing an ELF harden site in Wisconsin known as Project Sanguine. Project Sanguine was designed to communicate with submerged submarines. The ELF system used low-frequency waves to signal one-way coded messages to US and British Trident and Fast Attack submarines. The development of this ELF system encountered public concern over

the physical and environmental effects from electromagnetic radiation, which resulted in abandoning Project Sanguine. The ELF harden site would have consisted of over hundred unmanned transmitters measuring approximately 20 feet in diameter by 100 feet in length and would be all, underground. It would have had an operating frequency range of 72 Hz to 80 Hz. Each transmitter would operate autonomously and have its own emergency power supply. The antenna elements, 40 to 50 miles in length, would be buried 4-6 feet deep and would have 6000 miles of underground cable covering 6500 square miles.

- c. Surface ELF Antenna Addressing Remotely-deployed Receivers (SEAFARER) - Due to the cancellation of Project Sanguine, Project SEAFARER as was scheduled to begin development in May 1977. Consequently, on 16 February 1978, Project SEAFARER was cancelled President Carter. The proposed ELF system was very similar to Project Sanguine design. This system would have consisted of three above ground transmitters and have an operating frequency range between 72 Hz to 80 Hz. Each transmitter would operate autonomously and have its own emergency power supply. The antenna elements would have been 40 to 50 miles in length and buried 3.5 feet deep. The ELF system would require 2400 miles of underground cable covering 4700 square miles.
  
- d. AUSTERE ELF - The AUSTERE ELF project is a scaled down version ELF system. On March 1978, this project was proposed for development; however, the project faced resistance from the public and budget constraints the ELF system, which

resulted in not fielding the system. The AUSTERE ELF system consisted of one above ground transmitter, 130 miles of cable divided in three elements 32, 45, and 53 miles in length. The cables would be buried along public roads and other rights of ways.

### **3. EGAS SYSTEM DEVELOPMENT**

The design approach to the development of the EGAS system requirements requires an incremental build process. The build process is comprised of defining antenna structure and power requirements for underground ELF wave propagation, electromagnetic field (E-Field) subsurface signal loss over a 5000 km distance, minimum signal-to-noise detection, information bandwidth, operating frequency, and underground utilities that pose as a hazard or interfere in ELF subsurface wave propagation. These design points are essential in the development of EGAS system requirements and its architectural design. Standard system engineering practices shall be used throughout the EGAS development cycle.

#### **3.1 System Engineering Overview**

System engineering is a standardized, disciplined management process that evolves and verifies a system development effort or a life cycle balance set of system solutions that satisfy customer needs. This process also provides for simultaneous product (subsystem and component/modular) and process development and to ensure that all assigned engineering tasks are completed through project planning, tracking, and coordination. Systems engineering provides a structured process that transforms customer needs and requirements into a set of system and product specifications, system architecture, and configuration baselines; generates information for stakeholders (decision makers); and provides input for the next level of development. This process is applied sequentially,



adding detail and system and product definition at each stage or level of development. In Figure 3.1-1 System Engineering Design Process, the system engineering process consists of inputs and outputs, requirements analysis, Function Analysis/Requirements Flowdown, Requirements Loop, Synthesis, Design loop, Verification, and Reporting and Control. These are defined as follows:

- a. Process Inputs - These inputs pertain to the customer's needs, objectives, requirements, and project/design constraints.
- b. Requirements Analysis - This is the first step in the system engineering process. It is used to develop a set of functional and performance requirements and design constraints based on the customer's need or requirements.
- c. Functional Analysis/Requirement Flowdown - This step decomposes the system functional and performance requirements to subsystem and component/modular level functions. Key tools in function analysis and requirement flowdown are Functional Block Diagrams, Time Line Analysis, and Requirements Allocation Sheet.
- d. Requirements Loop - This is an iterative process that provides traceability of lower-level functional requirements to system level requirements.
- e. Product Design Development - This process defines the physical architecture and software of the product (Subsystem and Component/Modular) design based on

- functional requirement allocation. The development of the physical architecture provides the basic structure for generating design specifications and configuration baselines.
- f. Design Loop - This is an iterative design process that reviews and verifies that the physical product design meets the allocated functional and performance requirements.
  - g. Verification - This is an iterative verification process for which actual test results and analyses will be compared to customer's requirements, baseline documentation, and pass/fail criteria.
  - h. Reporting and Control - This process is a technical management activity, which measures the progress of the engineering development effort, document control, risk mitigation, and decision-making, and it evaluates alternative solutions.
  - i. Process Outputs – Process output pertains to any data development cycle that describes or controls the system and product configuration architecture and the baseline design documentation.

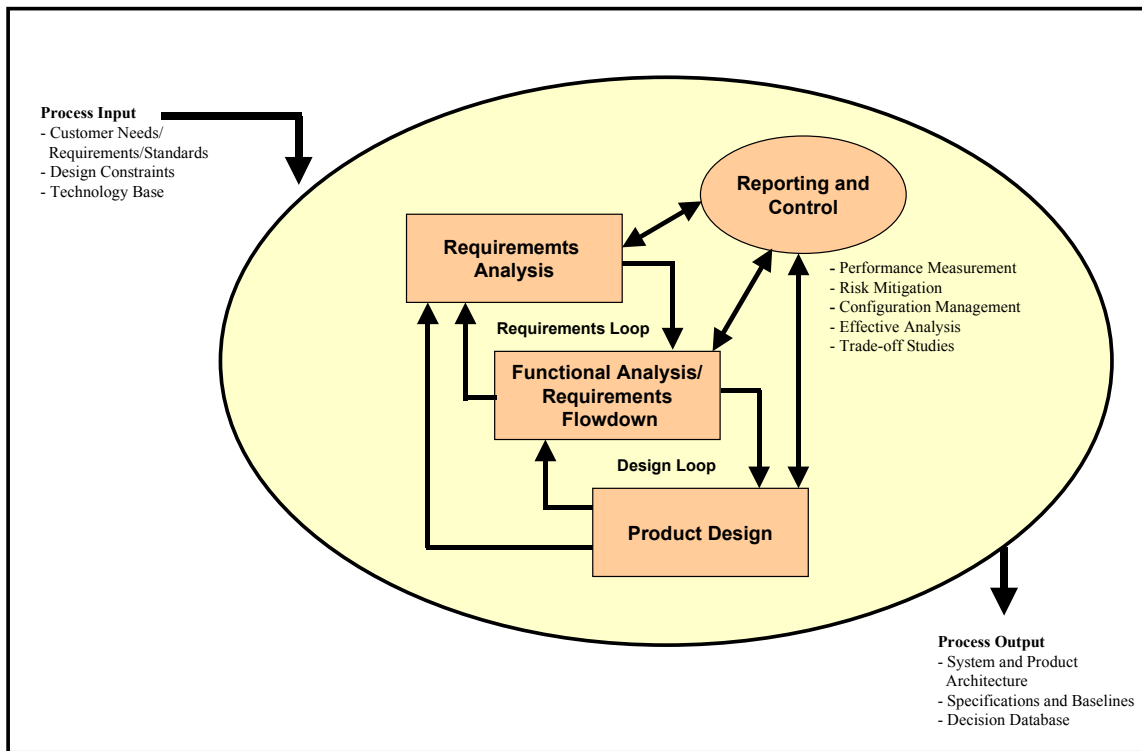

**Figure 3.1-1 System Engineering Design Process**

The EGAS design effort depends on integrating three major activities:

- a. Development Phasing – This phase is used to control the design process and provide baselines that coordinate system and product (subsystem and component/modular) design effort. The system engineering design process is partitioned into distinct stages or levels. Each stage represents a development phase, milestone, or a level of maturity of a system design or engineering solution. These stages relate to project planning, organizational structure, requirements analysis, functional analysis/allocation, milestone development, decision points, design reviews,

verification, and product delivery, which are used a control processes to facilitate development of an optimum system and cost effective design.

- b. System Requirements Flowdown - System engineering design process provides a structured environment for system requirements definition, solving design problems, requirements flow down to subsystem and component/modular level. The discipline of this process provides control and traceability to develop solutions that meet the customer's needs.
  
- c. Life Cycle Integration - This phase involves the customer in the design process, to ensure that the system and product design objectives are compliant with customer baseline and standard configurations.

### **3.1.1. Project Planning**

Project planning directly impacts planning decisions and establishes feasible methods to achieve design objectives. Project planning establishes an organizational structure to support the engineering development effort, identify the estimated funding, provide a detailed schedule necessary to achieve the technical strategy, develop an event-based schedule, and develop feedback and control methods. System engineering planning also establishes and maintains the interactive relationship between project management and technical management processes. Project management uses this planning activity to:

- a. Ensure that all technical activities are identified and managed
- b. Communicate the technical approach to a multi-disciplinary development team

- c. Document decisions and technical implementation
- d. Establish pass/fail criteria of design effort to meet customer needs.

### **3.1.2. Organizational Structure**

The project planning activity develops the organizational structure to support engineering development effort. Organizational planning determines the integration of the different technical disciplines, primary managers, and other stakeholders required to develop a system. The work breakdown structure (WBS) is used to organize system engineering development activities based on system and product decomposition (See Figure 3.1.2-1 Typical Work Breakdown Structure). It is used to structure development activities, to identify data and documents, to establish project management teams, and to organize Integrated Product Teams (IPTs). The WBS provides a structure for budgets, cost estimates, and cost reporting. A project management team is responsible for system definition and technical management. The IPTs are responsible for the cost, schedule, and performance of the team's product and documentation. An IPT is also considered a Reporting and Control tool because of its essential utility for all aspects of the system engineering process.

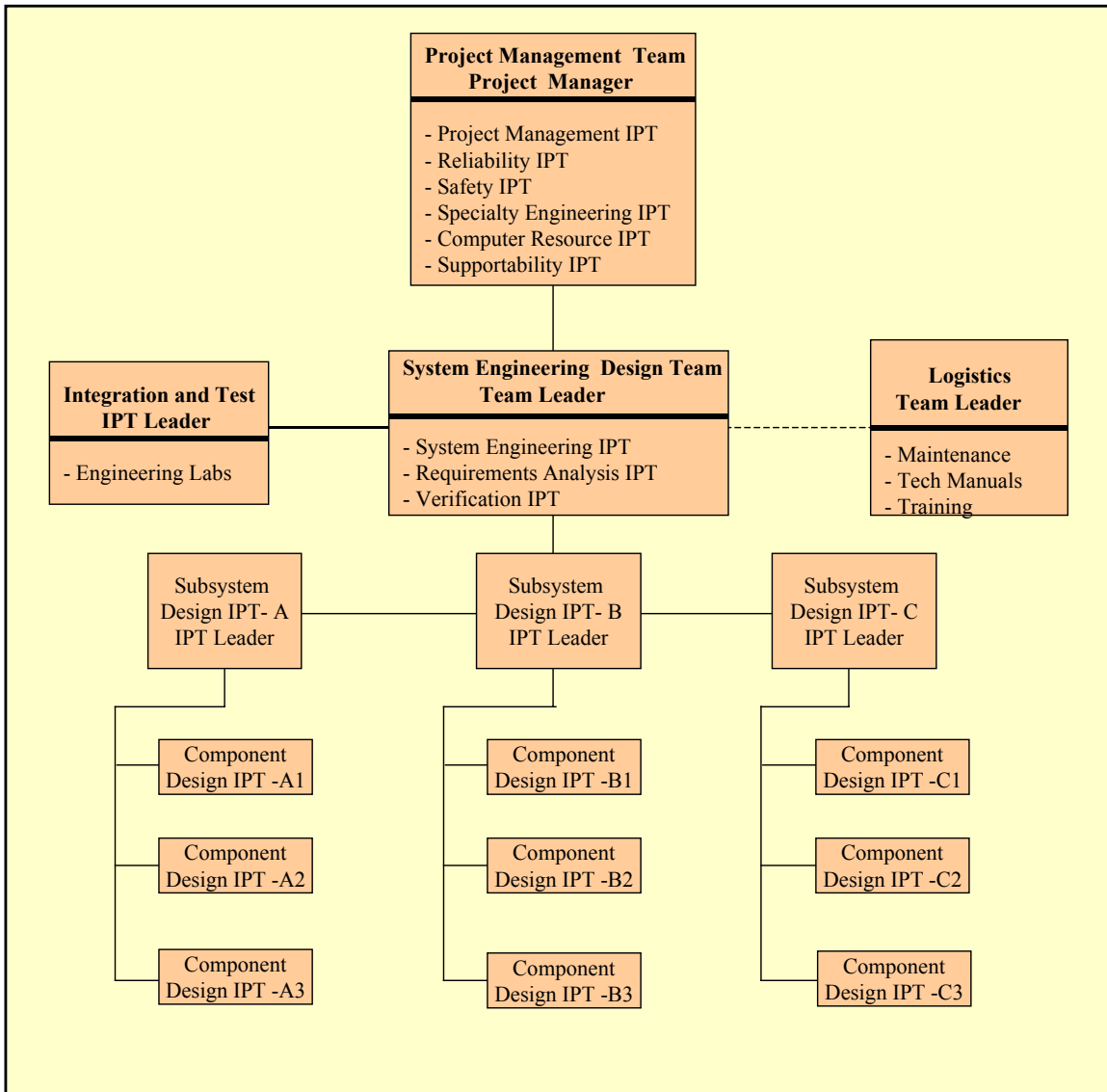

**Figure 3.1.2-1 Typical Organizational Structure**

### 3.1.3. Reporting and Control

To effectively manage an engineering development effort, a reporting and control process is required to ensure each development stage or phase meets the customer’s standards.

Reporting and control is a technical management process, which is used to measure progress, evaluate and select alternatives, document data, and make project decisions.

The reporting (also called systems analysis) activity evaluates alternative approaches to satisfy technical requirements, design objectives, performance criteria, functional and design requirements. The control activity assesses risk mitigation, and performs configuration management, data management, and performance-based progress measurement, including event based scheduling, and technical/design reviews. These activities are applicable to all stages and steps of the systems engineering process.

In Figure 3.1.3-1 -Reporting and Control Flow Decision Flow Diagram, shows a decision tree flow diagram that depicts the reporting and control process. This decision flow is initiated either by a Trigger (“T”), which represents a specific event, reporting time, milestone, or by an interruption in the engineering development process. The planning or review cycle begins by comparing the actual design data, data collection, or design documentation, based on a specific stage of development, to the customer’s requirements or standard.

Compliance is determined by assessing the variance between the planned (customer standard) to the actual data. The variance can positive or negative. If the variance is positive, then the design point is within the allocated standard deviation (performance tolerance) by customer, which is compliant to customer standards. If the variance is negative, the design point is not within the allocated standard deviation set by the customer. The data is re-verified for correctness. If the data still shows a negative variance, the data will undergo re-evaluation and diagnostics that may lead to a replan or

an alternative solution. Once an action has been declared to resolve this negative variance, or review will be scheduled.

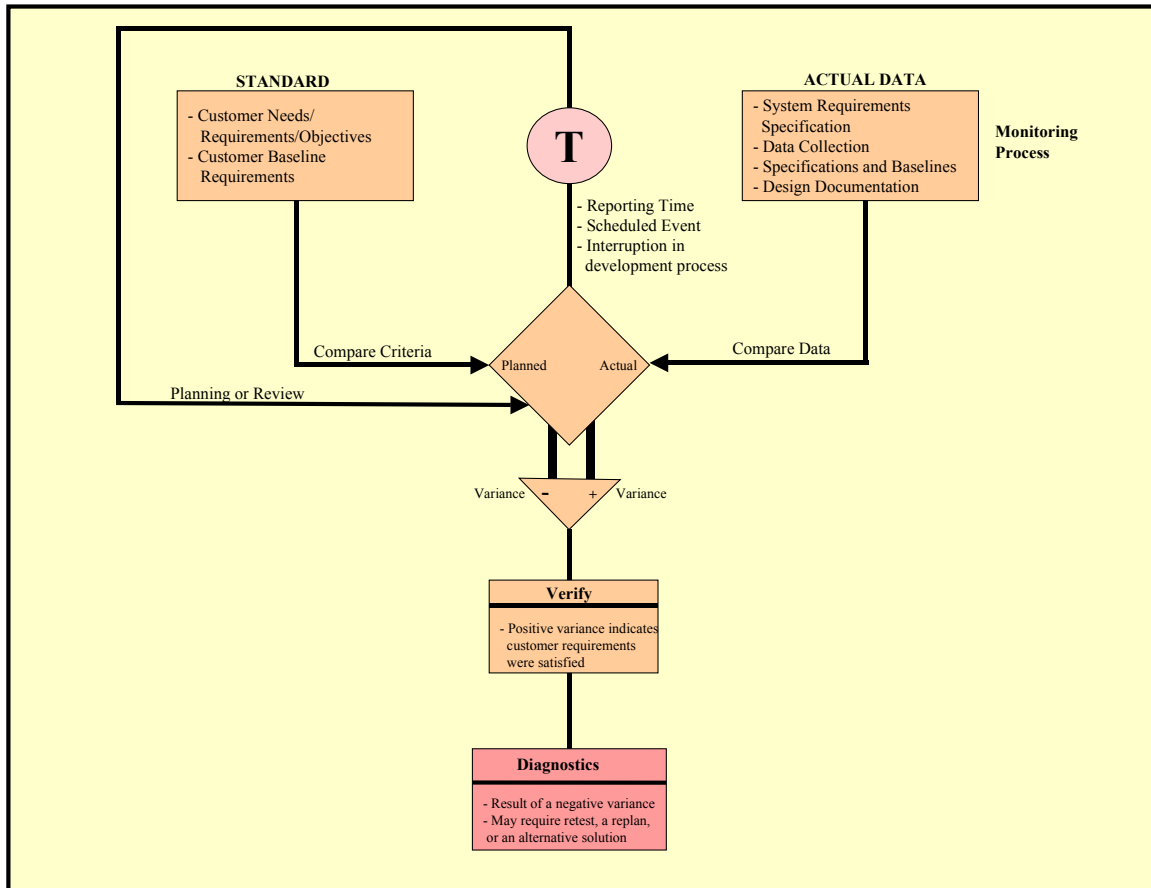

**Figure 3.1.3-1 Reporting and Control Flow Decision Flow Diagram**

### 3.1.4. IPDS Reporting and Control Diagrams

The Reporting and Control technical management process is used to measure the EGAS design progress by assessing key event-driven development points in a system engineering development schedule. Each key event has reporting and control activity that measures the progress of system and product performance and level of maturity. The



design is compared to pre-established customer exit criteria for each key event/technical review to determine if the appropriate level of maturity is achieved. The reporting and control decision flow diagram depicts the performance-based measurement and validation process for key events or technical reviews (See Figure 3.1.4-1 – Reporting and Control Decision Flow Diagram). Since there are 3 key events in Raytheon’s IPDS that apply to the EGAS conceptual design, these events which are Start-Up, SRR, and SDR are mapped into four reporting and control flow diagrams to show the progress measurement, data management, configuration management, and the selection of alternative solutions.

#### **3.1.4.1 Project Start-Up Reporting and Control Flow Diagram**

At start-up, EGAS project planning began and to development of the integrated master plan (IMP) integrated master schedule (IMS), to identify the technical risks, to define WBS, and to establish entry and exit criteria for each development stage. This reporting and control decision flow diagram shows the planning and review processes required to assess the proposed EGAS project plan/schedule data, risk mitigation, and organizational structure to customer needs and design objectives (See Figure 3.1.4.1-1 Project Start-Up Reporting and Control Flow Diagram).

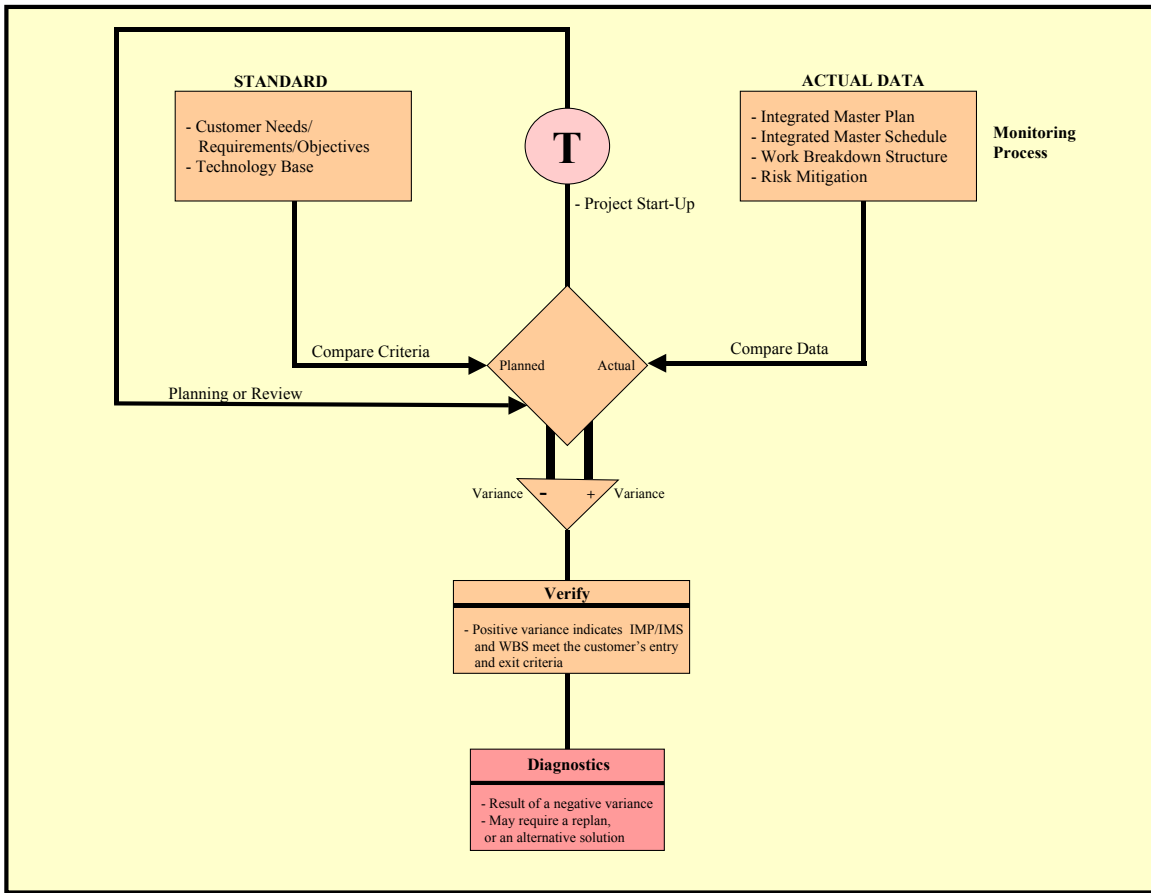

**Figure 3.1.4.1-1 Project Start-Up Reporting and Control Flow Diagram**

### 3.1.4.2 System Requirements Review (SRR) Reporting and Control Flow Diagram

The SRR review is used to establish the EGAS baseline configuration or preliminary design towards the development of a functional and physical architecture by allocating requirements to product and component levels. The reporting and control decision flow diagram depicts the review and decision process in the validation of system, software, and interface requirements specifications to establish a configuration baseline (See Figure 3.14.2-1 System Requirements Review (SRR) Reporting and Control Flow Diagram).

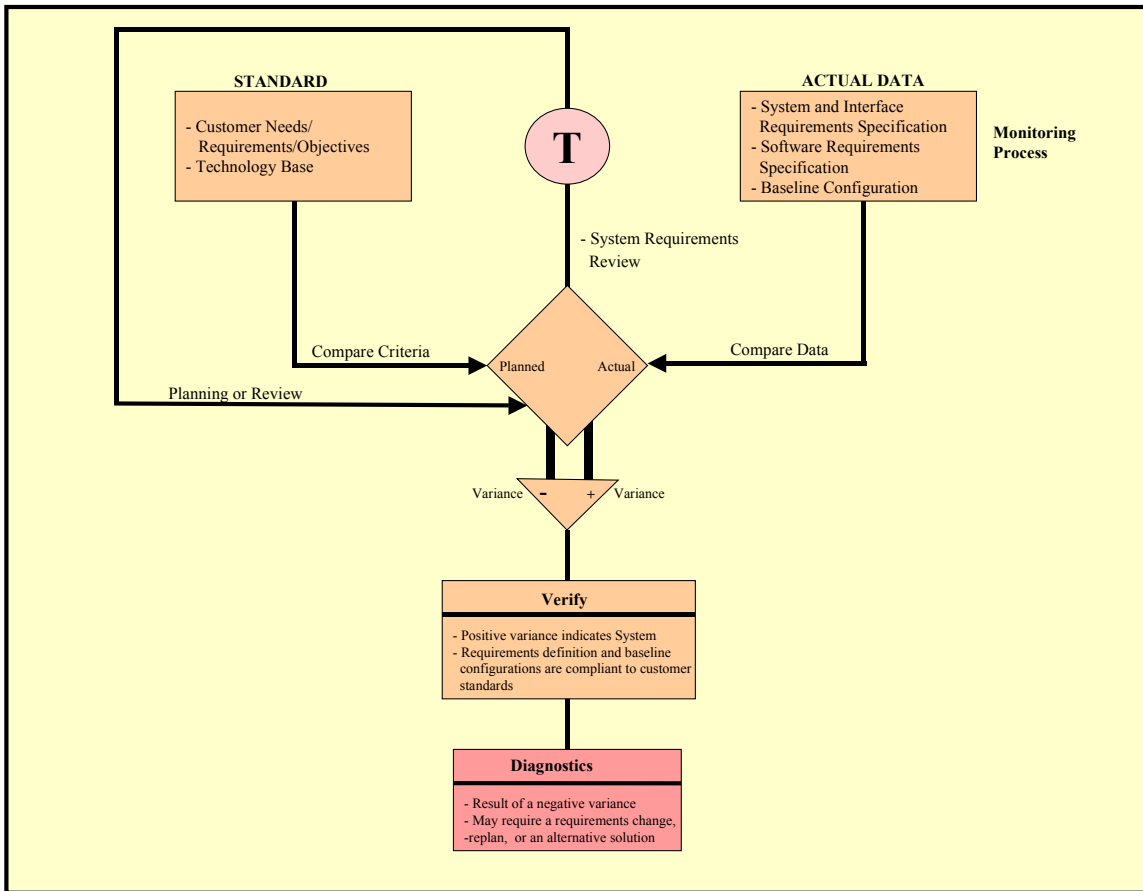

**Figure 3.1.4.2-1 System Requirements Review Reporting & Control Flow Diagram**

### 3.1.4.3 System Design Review (SDR) Reporting and Control Flow Diagram

The SDR reviews and defines EGAS system and product requirements, product baselines, software architecture, and functional requirements allocation to IPTs. The reporting and control decision flow diagram depicts the review and decision process in the validation of EGAS product baseline, proof of concept software architecture, and product requirements specifications to establish a product configuration baseline (See Figure 3.15.3 –1 System Design Review (SDR) Reporting and Control Flow Diagram).

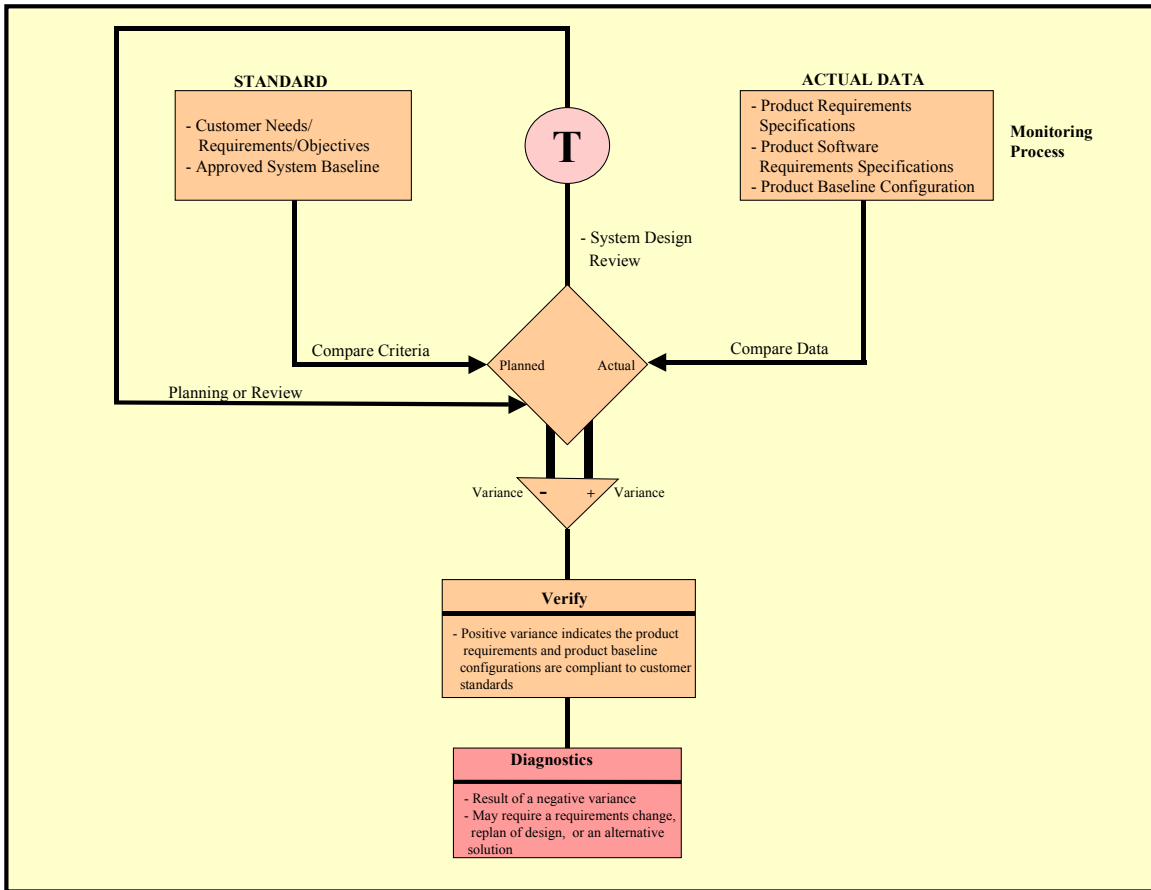

**Figure 3.1.5.3-1 System Design Review Reporting and Control Flow Diagram**

### 3.1.4.4 Preliminary Design Reviews Reporting and Control Flow Diagram

Preliminary Design Reviews (PDR) reviews and validates the detailed design of a system, including its physical and functional interfaces and risk mitigation. The reporting and control decision flow diagram depicts the review and decision process in the validation of a preliminary detailed design and system baseline (See Figure 3.1.4.4-1 Preliminary Design Reviews Reporting and Control Flow Diagram).

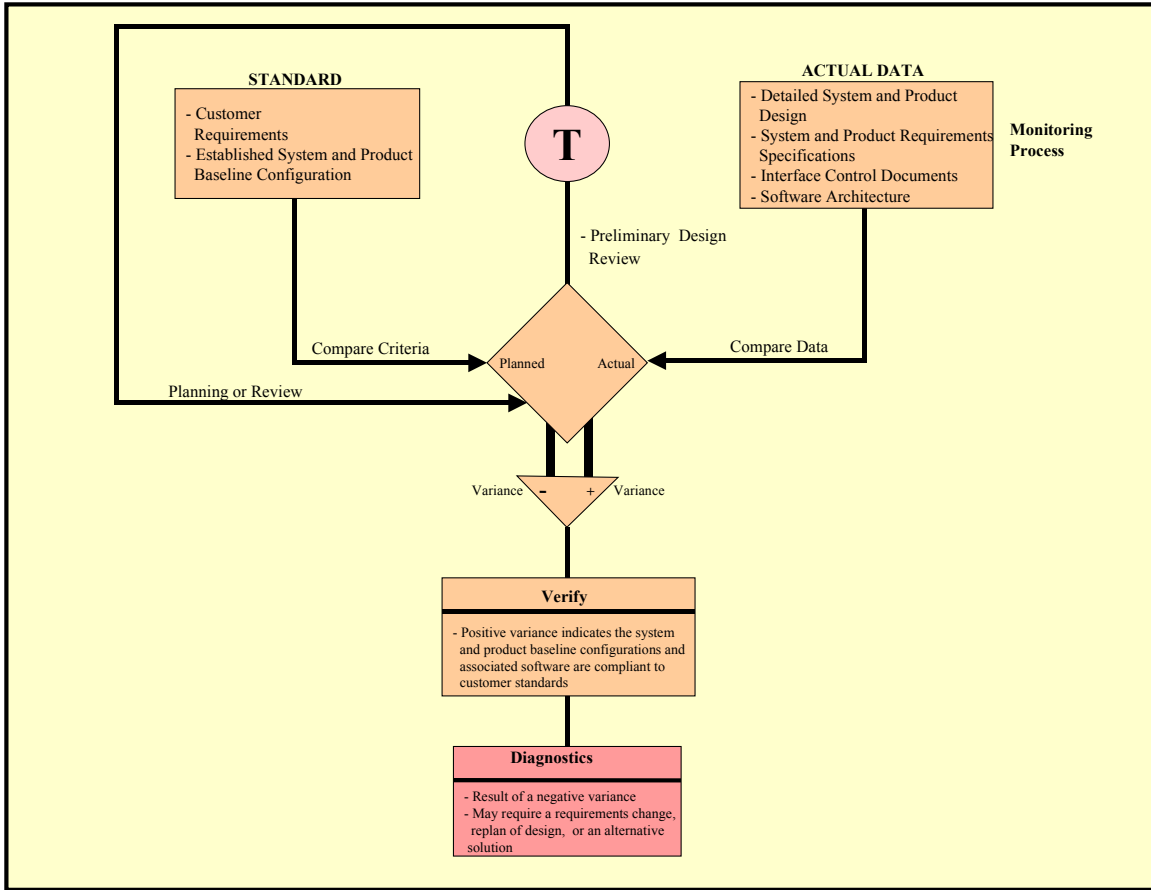

**Figure 3.1.4.4-1 Preliminary Design Review Reporting and Control Flow Diagram**

### 3.1.4.5 Critical Design Review Reporting and Control Flow Diagram

Critical Design Review (CDR) reviews and finalizes the detail design of the system and the physical and functional interfaces. This technical also ensures that design effort is operating within cost and schedule. The reporting and control decision flow diagram depicts the review and decision process in the validation of the detailed design and system baseline (See Figure 3.1.4.5-1 Critical Design Review Reporting and Control Flow Diagram).

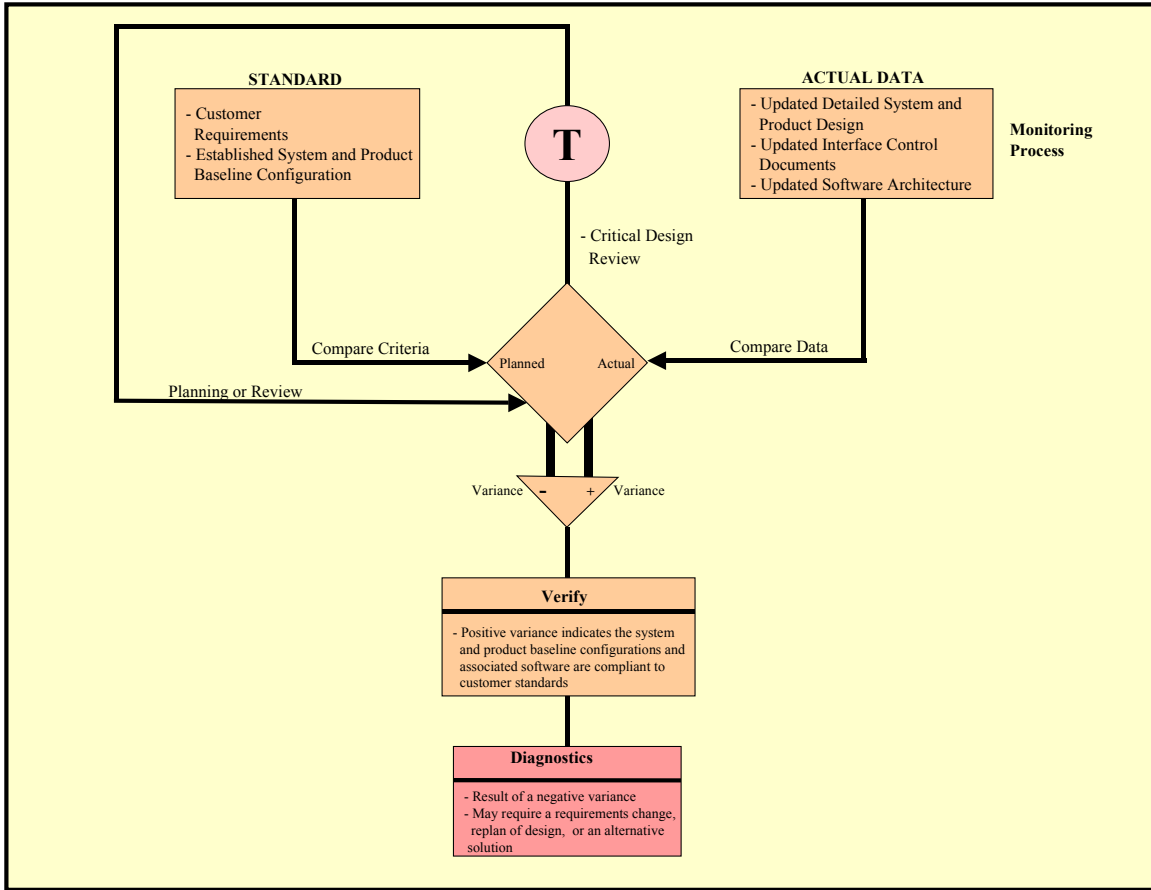

**Figure 3.1.4.5-1 Critical Design Review Reporting and Control Flow Diagram**

### 3.1.4.6 Test Readiness Reviews Reporting and Control Flow Diagram

Test Readiness Reviews (TRRs) reviews the verification of system, subsystem, and component requirements, including test procedure and performance model validation. The review also assesses test objectives, test procedures and resources testing coordination to ensure the verification of system and product test requirements. The reporting and control decision flow diagram depicts the review and decision process in the verification and validation of the system and product design (See Figure 3.1.4.6-1).

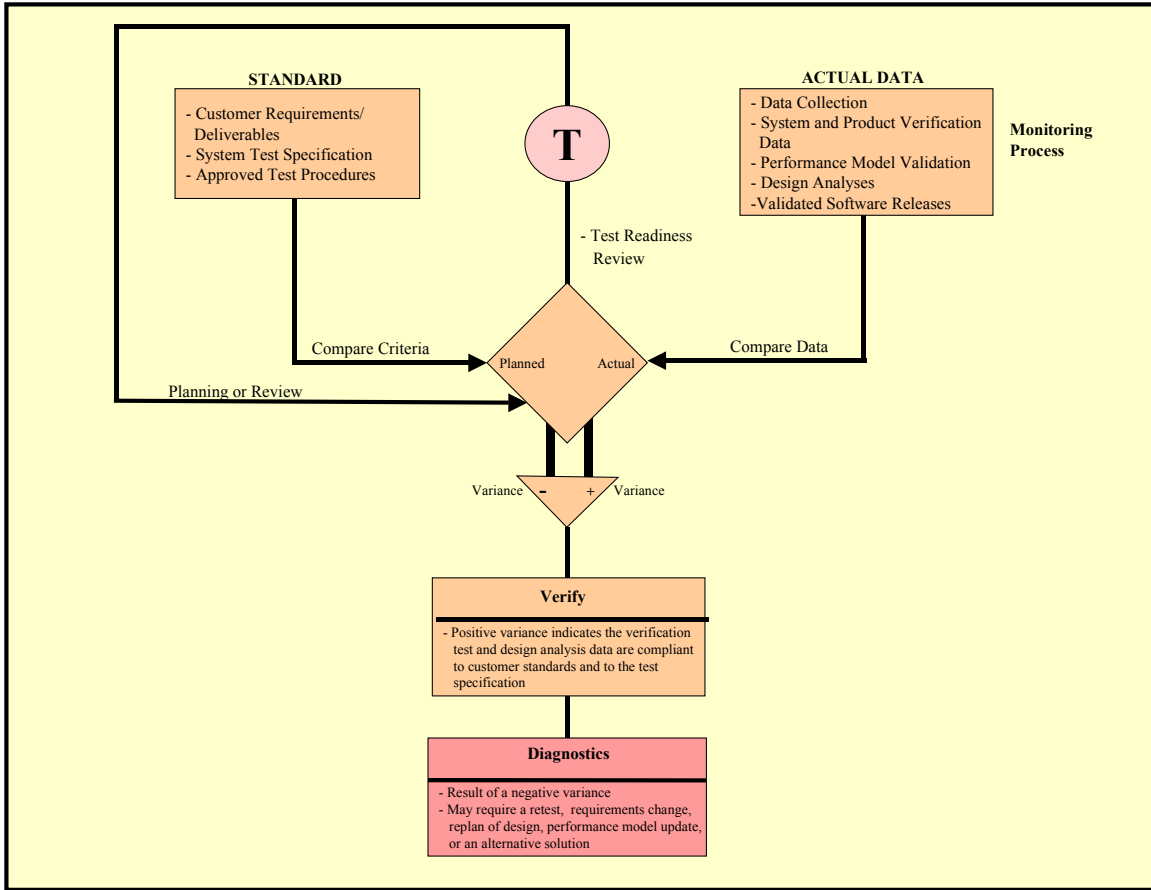

**Figure 3.1.5.6-1 Test Readiness Review Reporting and Control Flow Diagram**

### 3.1.4.7 Functional Configuration Audit Reporting and Control Flow Diagram

Functional Configuration Audit (FCA) is an audit and a system verification review that re-examines and verifies that all requirements baselined in the system and product specifications, associated test plans, and related documents were executed and verified with customer acceptance or corrective action/alternative solution. The reporting and control decision flow diagram depicts the review and decision process in the functional audit of the system (See Figure 3.1.4.7-1 Functional Configuration Audit Reporting and Control Flow Diagram).

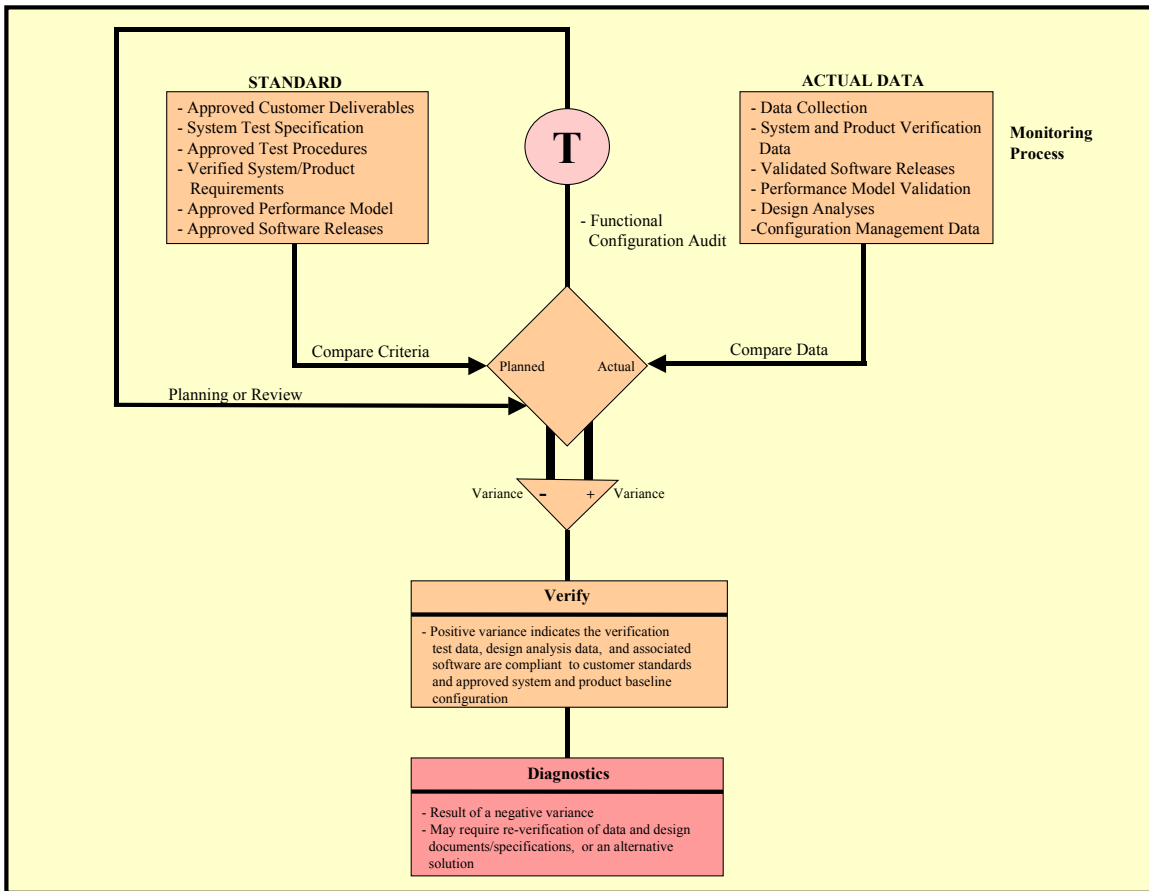
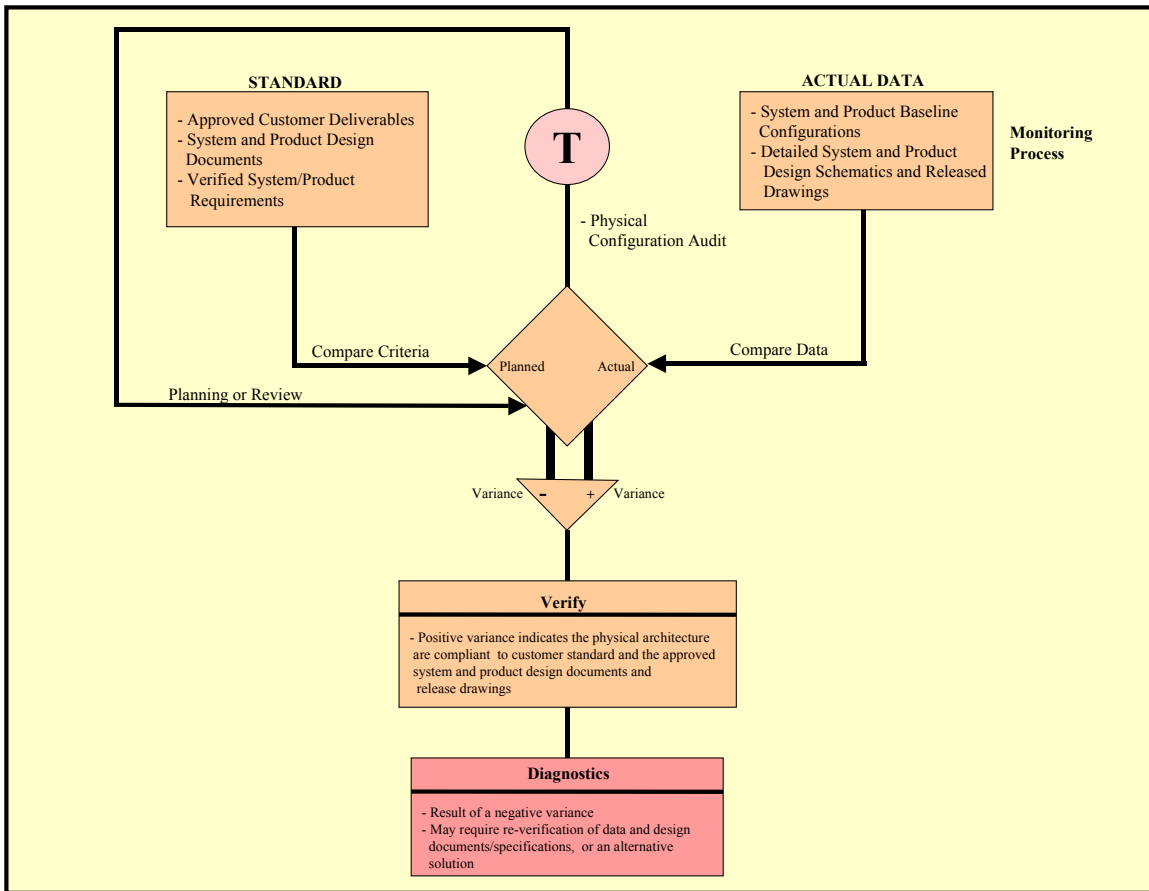

**Figure 3.1.4.7-1 Functional Configuration Audit Reporting and Control Flow Dgm**

### 3.1.4.8 Physical Configuration Audit Reporting and Control Flow Diagram

Physical Configuration Audit (PCA) is a review that verifies the physical architecture of the system and ensures that it's consistent with the technical data package, which describes the system baseline configuration. The reporting and control decision flow diagram depicts the audit and decision process in the physical architecture of the system (See Figure 3.1.4.8-1 Physical Configuration Audit Reporting and Control Flow Diagram).





**Figure 3.1.4.8-1 Physical Configuration Audit Reporting and Control Flow Dgm**

### 3.1.5. Key Events

Raytheon’s IPDS has 8 key events in its engineering development cycle: Project Start-Up, System Requirements Review (SRR), System Design Review (SDR), Preliminary Design Reviews (PDRs) Critical Design Review (CDR), Test Readiness Reviews (TRRs), Functional Configuration Audit (FCA), and Physical Configuration Audit (PCA). These key events represent technical reviews and decision points within the engineering development process (See Table 3.1.5-1 IMP Event Dictionary). These technical reviews assess and validate system and product design, technical risk, and

determine whether to proceed to the next level of development or milestone review.

Technical reviews also reduces risk by the following:

- a. Clarifying design requirements.
- b. Challenging the design and related processes.
- c. Checking proposed design configurations against technical requirements, customer needs, and system requirements.
- d. Evaluating the system configuration.
- e. Providing a form for communication, coordination, and integration across all disciplines and IPTs
- f. Establishing a common baseline, which proceed to the next level of design.
- g. Recording design decision rationale in the decision database.

**Table 3.1.6-1 IMP Event Dictionary**

Event	Purpose/Rationale
A. Business Capture (IPDS business capture, gates 1-4)	<p><b>Purpose:</b> Marks the beginning of the EGAS program</p> <p><b>Includes:</b></p> <ul style="list-style-type: none"> <li>• Establishes a time reference for the beginning of the program</li> <li>• Determines the scope, price, terms and conditions, and risk level to be assumed JP Industries</li> <li>• Winning bid/proposal and contract award</li> </ul> <p><b>Exit Criteria:</b> Execute the phase 5 ( post –submittal of the capture/proposal process</p>
B. Systems Requirements Review (SRR)	<p><b>Purpose:</b> This review defines the customer’s system requirements and to develop a system breakdown structure</p> <p><b>Includes:</b></p> <ul style="list-style-type: none"> <li>• Establish a configuration baseline.</li> <li>• Define constraints</li> </ul> <p><b>Exit Criteria:</b> System specifications completed and approved by customer</p>

Event	Purpose/Rationale
C. System Design Review (SDR)	<p><b>Purpose:</b> This review defines system definition for product requirements flowdown, and the establishment of a Work Breakdown Structure (WBS) to the customer.</p> <p><b>Includes:</b></p> <ul style="list-style-type: none"> <li>• Conduct trade studies</li> <li>• Risk Assessment on long-lead items</li> </ul> <p><b>Exit Criteria:</b> Provide a design review package</p>
D/M. EGAS Prototype Demonstration	<p><b>Purpose:</b> This demonstration simulates the two - way ELF subsurface communication concept of EGAS for customer review and acceptance</p> <p><b>Includes:</b></p> <ul style="list-style-type: none"> <li>• Masters Project presentation on EGAS prototype performance</li> <li>• A EGAS Masters Report Submittal</li> </ul> <p><b>Exit Criteria:</b> Acceptance of prototype design and precede with PDR</p>
D. Preliminary Design Review (PDR)	<p><b>Purpose:</b> This review provides the customer with a detailed design approach of the EGAS system.</p> <p><b>Includes:</b></p> <ul style="list-style-type: none"> <li>• Risk Assessment on the design</li> <li>• Define physical and functional interfaces Home Design - Drawing for Review</li> <li>• EGAS Product Design - Final Changes</li> </ul> <p><b>Exit Criteria:</b> Detailed design completed and reviewed with the IPTs</p>
E. Critical Design Review	<p><b>Purpose:</b> This review provides the customer with a more mature detailed design of the EGAS and the physical and functional interfaces the product build.</p> <p><b>Includes:</b></p> <ul style="list-style-type: none"> <li>• Test planning and preparation</li> <li>• Update Risk mitigation</li> <li>• Order long lead items for integration and test</li> <li>• Begin test procedure development</li> <li>• Complete software design</li> </ul> <p><b>Exit Criteria:</b> Customer approve the detailed design for system and product build</p>

Event	Purpose/Rationale
F. Test readiness Review) (TRR)	<p><b>Purpose:</b> This review provides the customer with the integration, verification, and validation data and schedule for witness and customer acceptance.</p> <p><b>Includes:</b></p> <ul style="list-style-type: none"> <li>• Begin integration of EGAS products</li> <li>• Begin integration of EGAS components</li> <li>• Complete Incremental testing (test builds)</li> <li>• Complete Site Surveys of designated antenna sites</li> <li>• Excavation of field sites to bury transmit and receive antennas</li> <li>• Witness and approve verification and validation (operation and performance) testing of the EGAS system, to include product/component designs</li> <li>• Have a FCA on all verification test results</li> <li>• Hold a PCA to match released drawing to actual EGAS hardware.</li> </ul> <p><b>Exit Criteria:</b> The customer reviews approves all system requirements were properly verified and met the all performance and operational requirements for customer acceptance.</p>
G. Functional Configuration Audit (FCA)	<p><b>Purpose:</b> This audit provides the customer to review all verification and validation (system performance and operational test) data for acceptance.</p> <p><b>Exit Criteria:</b> The customer approves the FCA</p>
H. Physical Configuration Audit (PCA)	<p><b>Purpose:</b> This audit provides the customer to review all released drawings and physically compares the released drawings to the actual EGAS hardware.</p> <p><b>Exit Criteria:</b> The customer approves the PCA</p>
I. Delivery	<p><b>Purpose:</b> Provides the tasks to deliver or DD 250 the EGAS to the customer</p> <ul style="list-style-type: none"> <li>• Closing on the house</li> </ul> <p><b>Exit Criteria:</b> All paper work signed for closure for DD 250 of the EGAS</p>

### 3.2 Technical Approach

The ELF frequency band was selected due its long-range communication capability and penetration characteristics through seawater and the earth's crust. To propagate ELF beneath the earth's surface at great distances, require an enormous antenna structure, a

large radiated power output, and a very sensitive receiver. ELF transmissions are very slow, due to its narrow bandwidth, which affect the data rate of information. Slow Continuous Wave (Morse Code) or phase shift-keying (PSK) modulation, which is binary character transmission, is basically all that is practical. Bandwidth for this ELF band typically ranges from 10 Hz to 30 Hz.

Prior to the development of the EGAS System Requirements Specification (SRS) and EGAS architectural design, there are signal processing and propagation characteristics that have to be identified to effectively conduct two-way ELF subsurface communication. These characteristics are determined by identifying the skin depth ( $\delta$ ), operating frequency, transmitter power, subsurface E-Field attenuation loss, and minimum signal detection through the earth's crust or medium over a distance of 5000 km.

- a. Skin Depth – Skin depth is a signal penetration depth value, which is determined from the characteristics of the earth's crust. The variation in depth is dependent on the earth's resistivity (electromagnetic field), earth's permeability, type of soil, and frequency of the communication signal. This value will be used to determine how deep to bury the system.
- b. Operating Frequency Selection – The selection of the EGAS operating frequency is very important. The intent is to achieve the lowest ELF frequency possible for optimum penetration through earth or lossy medium without being affected by harmonic distortion or electromagnetic interference.

- c. Transmitter Power – Determine the minimum amount of transmitter power (Watts) required to penetrate through the earth’s crust over a distance of 5000 km.
  
- d. Subsurface E-Field Attenuation Loss - After the transmitter power required to penetrate to the earth’s surface has been defined, determine the E-Field signal attenuation loss through the earth’s crust across 5000 km. The signal attenuation (dB) loss will vary based on soil content, moisture and depth.
  
- e. Minimum Signal Detection - Determine the minimum received signal-to-noise (S/N) ratio at the detector input of for signal processing. The minimum S/N ratio is determined based on the signal attenuation loss through soil content (Texas geological data), the burial depth as the result of the skin depth calculation, and ELF wave propagation through the earth’s crust.

### **3.2.1. E-Field Calculations**

The calculation of the skin depth, E-field attenuation loss through the earth’s crust at a distance of 5000 km, and the minimum the ELF signal detection are very critical to system requirements development, and architectural design of the system. The results of these calculations define the limitations to the selection of an optimum operating frequency, transmitter power and current output, bandwidth, and antenna length. The subsurface antenna propagation calculations for infinitesimal horizontal dipole utilizes

derived Maxwell's equations, which are used to determine the values of skin depth, E-field attenuation loss, and minimum the signal detection are as follows:

- a. Calculate Skin depth.

Skin depth is the ground penetration depth based of ELF signal.

$$\delta = (2/\omega * \sigma * \mu)^{1/2} = \text{Skin depth (meters)}$$

$\omega$  = Radian frequency of the signal (rad/sec)

$\sigma$  = Electrical conductivity of a medium (Rock) =  $10^{-2}$  Siemens/m (S/m)

$\mu = \mu_0$  = permeability of free space/rock =  $1.2566 \times 10^{-6}$  W/Am

- b. Calculate E-Field Attenuation Loss through the earth's crust over a distance of 5000 km.

To determine the ELF subsurface signal loss, the E-Field equation has to model the attenuation characteristics of a buried horizontal turnstile antenna.

Calculating the magnitude of this E-Field equation provides the signal transfer function. The MATLAB results depict the E- Field attenuation loss in terms of minimum receiver sensitivity (dB $\mu$ V) required for detection. The receiver sensitivity (dB $\mu$ V) is converted into dBm.

$$E = \exp^{k*hf} [ \eta * I * dl / 2\pi r^2 (1 + ik_0) * (\theta * \cos\phi - \Psi * \cos\theta \sin\phi) \exp^{ik_0 * r} ]$$

= E-Field Attenuation loss over a 5000km distance (volts/meter)

$k = [-i\omega * \sigma * \mu]^{1/2}$  = propagation constant

hf = Burial depth of antenna (meters)

$\eta = (\omega * \mu) / k =$  Surface Wave Impedance of the earth's crust or medium (Ohms)

$I = [P/R]^{1/2} =$  Current in the antenna element (Amperes)

$P =$  Transmitter Power (Watts)

$R = ((\eta * 2\pi) / 3) * ((dl/\lambda)^2) =$  Radiation Resistance for an infinitesimal dipole (Ohms)

$\lambda = c/f =$  wavelength the of signal (meters)

$f =$  frequency (Hz)

$c = 3 * 10^8$  m/sec = speed of light

$dl =$  The length of antenna element = length of dipole antenna (50 kms)

$i =$  imaginary component

$k_0 = \omega * (\epsilon_0 * \mu)^{1/2} =$  Propagation constant for free space

$r = 5000$  km distance

$\theta =$  Zenith angle to radial distance

$\phi =$  Phase angle

$\Psi = (2\pi * f / \lambda) * -\omega t =$  Electrostatic potential (volts)

$t = 1/f =$  time

c. Calculate Minimum Signal Detection.

The minimum signal detection is to determine the received signal-to-noise (S/N) ratio at the detector input. The sum of the E-Field attenuation loss (dBm) and the skin depth (dBm) represents the total signal (S) loss over a distance of 5000 km. To determine the signal-to-noise (S/N) relationship, divide the total signal (S) by the noise (N) of the receive antenna.



$S/N$  = Signal-to-Noise ratio at the receiver detector input

$S = E \text{ (dB)} + \delta \text{ (dB)}$  = Total signal loss over a 5000 km range (dB)

$N = k_n * T * B$  = Noise figure (dB)

$k_n = 1.38 * 10^{-23}$  Boltzmann's Constant (Joules/Kelvin)

$T = 290 \text{ K}$  = Temperature of turnstile antenna (Kelvin)

$B$  = Bandwidth (Hz)

### 3.2.2. Results of E-Field Calculations and Analysis

A MATLAB program was developed to calculate skin depth, E-Field attenuation loss, and minimum signal detection. The program solved for skin depth (dB), E-Field attenuation at 5000 km (dBm), sums up all the losses (dB), minimum signal detection in term of signal-to-noise (dB), Differential Phase Shift Keying (Modulation) threshold, and receiver detector performance based on detection performance requirement. The transmitter output power, dipole antenna length, and ELF frequency were variables in the program. This manipulation of variables were be used to determine the lowest transmitter power and current output, system operating frequency, and information bandwidth. Based on the operating frequency selection, the appropriate bandwidth was determined.

The results of the MATLAB program reveal that transmitting at 200W and operating between 215 Hz to 225 Hz at bandwidth of 10 Hz with a RMS detection performance of 5.7 dB using a turnstile horizontal antenna length of 50 km is the best combination (See

Table 3.2.3-1 EGAS E-Field Subsurface Wave Propagation Characteristics Results).

These results are used to establish EGAS functional requirements and design parameters.

Design Point Parameters	220 Hz Operating Frequency	225 Hz Operating Frequency	230 Hz Operating Frequency
Transmitter Power	200 W	200 W	200 W
Skin Depth (sigma)	339.3 m	335.3 m	331.9 m
Antenna Burial Depth	10 m	10 m	10 m
E-Field Attenuation Loss through 5000km of Earth Medium	(-76.81 dBm)	(-77.2 dBm)	(-77.5 dBm)
EGAS Reciever Minimum Detection Limit	(-120 dBm)	(-120 dBm)	(-120 dBm)
Receiver Minimum Signal Detection	(-113.7 dBm)	(-114.3 dBm)	(-114.29 dBm)
Transmission Distance	5000 km	5000 km	5000 km
Transmitter Current per X and Y feedline	206.4 Amps	200.7 Amps	195.25 Amps
Dipole Radiation Resistance	1.2 micro-Ohms	1.2 micro-Ohms	1.3 micro-Ohms
EGAS Bandwidth	10 Hz	10 Hz	10 Hz
Differential Phase Shift Keying (DPSK) Threshold	73.98 dB S/N	73.97 dB S/N	73.92 dB S/N
Signal-to-Noise ratio at Detector Input	80.3 dB S/N	79.7 dB S/N	79.1dB S/N
Detection Performance	(+6.32 dB) S/N	(+5.73 dB) S/N	(+5.08 dB) S/N

**Table 3.2.3-1 EGAS E-Field Propagation Characteristics Results**

### 3.3 Design Considerations

#### 3.3.1. Assumptions

To illustrate the concept of ELF subsurface wave propagation and the EGAS prototype design, the following assumptions are defined. The transmission of ELF waves through the earth’s crust defies the rules of the wave propagation properties of free space.

Conductivity of earth media plays a major role in designing this prototype. The conductivity of the earth varies with the composition of the earth materials. The subsurface propagation model is based on the assumption that the earth is uniform in its electrical properties. The earth medium and its electrical conductivity for this EGAS prototype design effort shall be represented by the geological characteristics of Texas (See figure 3.3.1 –1 Geological Map of Texas).

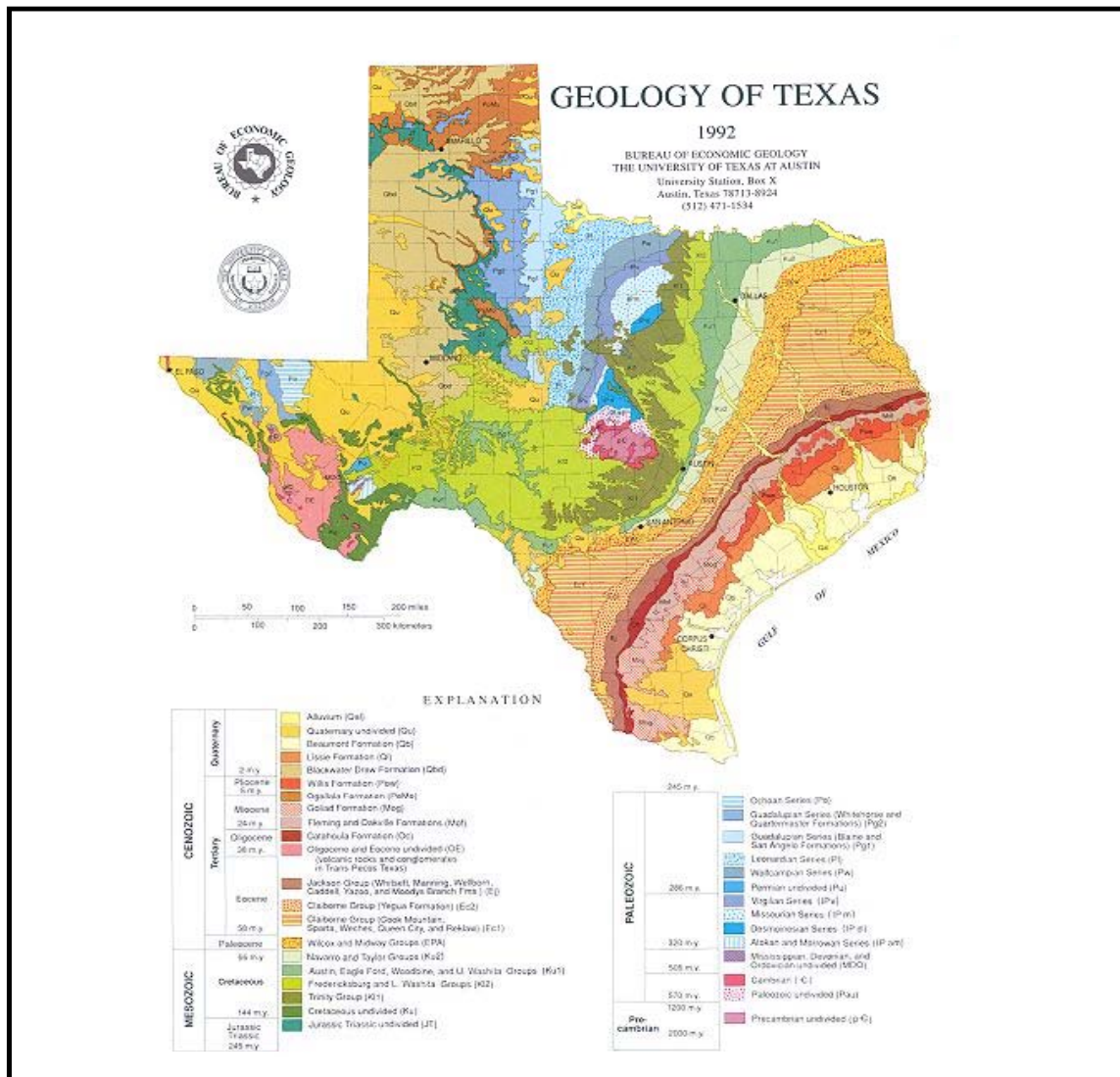

**Figure 3.3.1-1 Geological Map of Texas**

The crust of the earth in Texas is primarily composed of unconsolidated sediments, sandstone, shale, limestone, and granite. The electrical conductivity of these geological materials is different. After reviewing the conductivity of these rock materials and the burial depth of the EGAS system, the electrical conductivity mean value for a rock medium, which is  $1 \times 10^{-2}$  Siemens/meter (S/m), shall be used (See Table 3.3.1-2

Electrical Conductivity of the Earth). The electrical conductivity value  $\sigma$  (sigma) will be used in penetration depth and electromagnetic field strength/sensitivity calculations.

**Table 3.3.1-2 Conductivities of the Earth**

<b>Conductivities of Earth Media</b>	
<b>Conductivity (S/m)</b>	
<b>Medium</b>	<b>Typical</b>
Rock	$10^{-1}$ to $10^{-3}$
Soils	$10^{-2}$ to $10^{-3}$
Sea Water	4
Fresh Water	$10^{-2}$ to $10^{-4}$
Coal	$10^{-2}$ to $10^{-3}$
Ice (glacial)	$10^{-4}$ to $10^{-6}$
Permafrost	$10^{-4}$ to $10^{-5}$

### 3.3.2. Design Constraints

To effectively propagate ELF waves beneath the earth’s surface, several factors or constraints have to be considered. These factors or constraints impact the EGAS prototype design and ELF subsurface wave propagation are power distribution systems, electrical power line harmonic interference and resonance distortion, telephone operations, railway signaling systems, underground pipelines, and the specification of ELF operating frequencies.

- a. Power Distribution Systems: ELF subsurface transmissions may pose a safety hazard to AC power distribution systems due to its induced current on a neutral wire or power cable. To prevent potential activation of protective relays within a power distribution system, it is essential that the transmit antenna location is not

close to power distribution lines. Additionally, 200 Hz notch filters will be installed in the lines to reduce the induced carrier current, if the lines must pass within several miles of the transmit antenna's near field. In reference to the receiver system, high voltages can be built up on the receive antenna if it is located close to AC distribution lines. Notch filtering is used in the receiver to remove much of the 50/60 Hz fundamental prior to amplification of the ELF.

- b. Electrical Power Line Harmonic Interference: The 50 Hz (European electrical power frequency), 60 Hz (United States electrical power frequency), and 3-Phase AC power fundamental frequency and their 3<sup>rd</sup>, 5<sup>th</sup>, 7<sup>th</sup>, 11<sup>th</sup>, and 13<sup>th</sup> harmonic resonance frequency will interfere with ELF subsurface wave propagation. To neutralize the 50/60 Hz fundamental frequencies and the harmonic resonance, the EGAS shall have 50/60 Hz notch filters and harmonic filters incorporated into the ELF receiver design
  
- c. Telephone Networks: There is a potential hazard presented by the voltage induced in the telephone lines. Since telephone systems are typically grounded only by a central exchange, the induced voltage to ground can increase continuously along subscriber lines, and cause spurious ringing at the telephone, especially in party lines in rural systems. As in the case of power distribution systems above, 200 Hz notch filters will be installed in long telephone lines to minimize current buildup from the transmitted carrier.

- d. Pipelines/ Railway Signaling Systems: Pipelines buried beneath the surface pose as a safety hazard due to potential leakage, which contain corrosive, toxic, and flammable properties. This potential leakage may physically damage antenna, the feedline cables/connectivity, and system performance. Also, high currents can be induced in pipelines close to the transmit antenna. Insulated sections in the pipe system can be used to break up the carrier current in the pipe. Railway signaling systems also pose as a potential hazard. The railway signaling systems produce a tremendous amount of voltage, and the surface beneath the railway track serves as a ground return.

To eliminate these two potential hazards, the EGAS antenna elements shall be protected by the use of Polyvinyl chloride (PVC) conduits. The PVC electrical conduits provide insulation, corrosion/fire protection, and shielding against electrical conductivity and voltage ties to the ground. The railway signaling systems typically use DC voltage as a transmission medium. Because of this, 200Hz notch filters in series and in parallel will be used to eliminate any AC induced into the signaling system by the EGAS transmitter.

- e. Operating Frequency Selection: Selecting an optimum operating frequency for the EGAS requires reviewing all known constraints with respect to underground electromagnetic propagation, potential hazards to the design, and to ensure safety to the populace. The results concluded that the power distribution line's 50/60 Hz fundamental frequency, 2<sup>nd</sup>, and 3<sup>rd</sup> order harmonic resonance frequencies cannot

be used as an operating frequency due to interference. (The 1<sup>st</sup>, 2<sup>nd</sup>, 3<sup>rd</sup>, and 5<sup>th</sup> harmonic resonance for 50 Hz is 50Hz, 100 Hz, 150 Hz, and 200 Hz. The 1<sup>st</sup>, 2<sup>nd</sup>, 3<sup>rd</sup>, and 5<sup>th</sup> harmonic resonance for 60 Hz is 60 Hz, 120 Hz, 180 Hz, and 240 Hz.) The lowest ELF operating frequencies that are not subject to harmonic distortion or electromagnetic interference range between 210 Hz and 230 Hz. For purposes of this EGAS prototype design, the operating frequency shall range from 215 Hz to 225 Hz with a bandwidth of 10 Hz.

### **3.4 EGAS System Requirements Development**

To develop system requirements for the EGAS, initially, requires identifying that the minimum signal detection, transmitter power, and the attenuation losses through the earth's crust over a range of 5000 km be already identified. Knowing these factors is critical to the establishment EGAS functional requirements, design parameters, and constraints. These propagation characteristics are also used in the development of functional and physical block diagram (See Figure 3.4-1 and 3.4-2). This leads to the development of the EGAS System Requirements Specification (SRS) (See Table 3.4-3 - EGAS System Requirements). The validation of these system requirements provides an EGAS baseline or preliminary design towards the development of EGAS functional and physical architecture by allocating requirements to product and component levels.

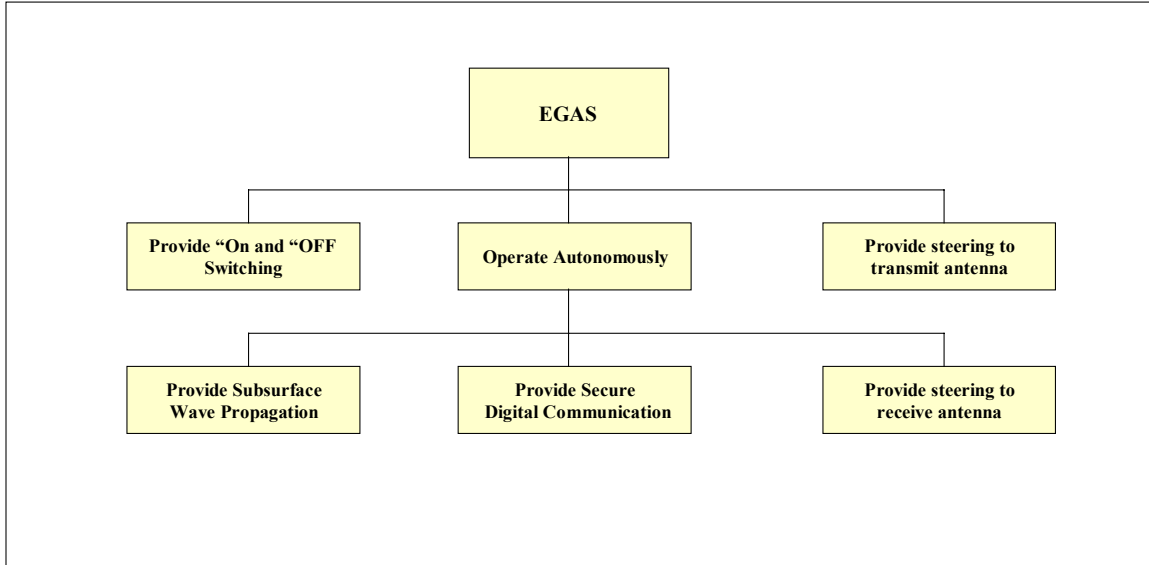

**Figure 3.4-1 EGAS Functional Block Diagram**

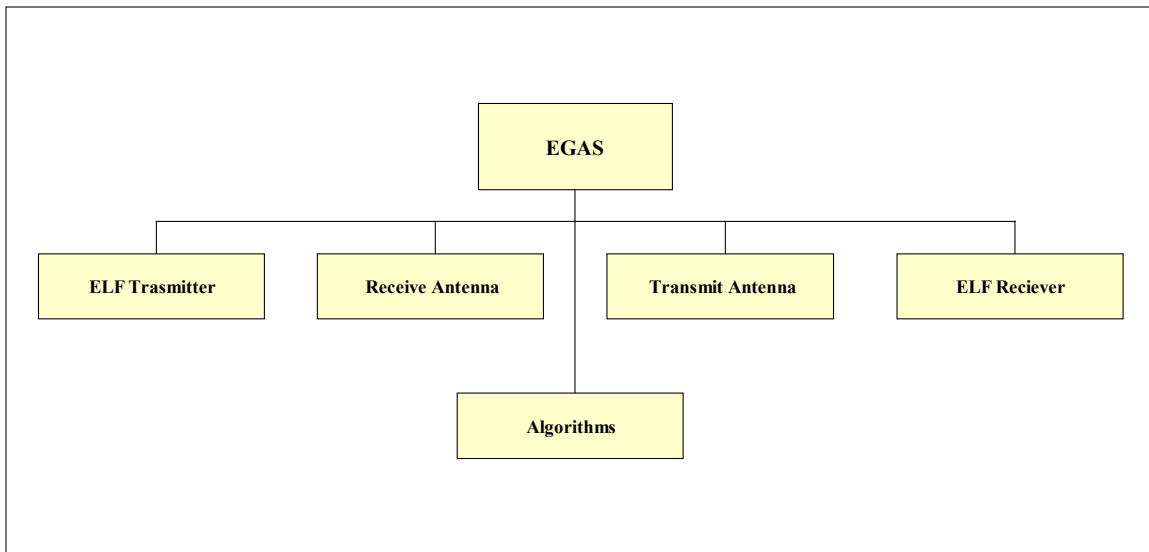

**Figure 3.4-2 EGAS Physical Block Diagram**



## Extremely Low Frequency Global Alert System (EGAS) Requirements List

**Method Legend: INS- Inspection      ANA - Analysis**  
**DEM - Demonstration    TST - Test**

Req. ID	Para	Title	Text	VM
A001	3.2.1.1	EGAS Operating Frequency	The EGAS operating frequency shall be contained in the range of 215 Hz to 225 Hz with a 10 Hz information bandwidth.	TST
A002	3.2.1.2	EGAS Operating Range	The operating range of the EGAS shall be 5000 km (3106.9 miles) in all directions.	TST
A003	3.2.1.3	EGAS Frequency Allocation	The EGAS shall meet the FCC guidelines for frequency allocation.	TST
A004	3.2.2.1	Transmit Antenna Length	The transmit antenna length shall not exceed 50 km (31.5 miles).	TST
A005	3.2.2.2	Transmit Antenna Configuration	The transmit antenna shall consist of two dipole antennas orthogonal to one another.	TST
A006	3.2.2.3	Location of Transmit Antenna	The transmit antenna shall be placed underneath the earth's surface at a depth greater than or equal to 10m (32.8 ft).	TST
A007	3.2.2.4	Steering of Transmit Antenna	The transmit antenna shall be steerable in azimuth in all directions to optimize signal gain and maximize directivity.	TST
A008	3.2.2.5	Horizontal Polarization of Transmit Antenna	The transmit antenna shall be only horizontally polarized.	TST
A009	3.2.2.6	Transmit Antenna Feeder Line	The transmit antenna feeder line for each antenna shall nominally be 73 Ohms.	TST
A010	3.2.2.7	Transmit Antenna Gain	The transmit antenna gain shall be nominally 2.14 dBi.	TST
A011	3.2.2.8	Transmit Antenna Feeder Loss	The transmitting feeder system loss shall be limited to least 1 dB.	TST
A012	3.2.2.9	Transmit Antenna Clearance	The transmit antenna shall have a clearance distance of ~1 to 3 km (~3000 to 9000 ft).	TST
A013	3.2.3.1	Receive Antenna Length	The receive antenna length shall not exceed 50 km (31.5 miles).	TST
A014	3.2.3.2	Receive Antenna Configuration	The receive antenna shall consist of two dipole antennas orthogonal to one another.	TST
A015	3.2.3.3	Location of Receive Antenna	The receive antenna shall be placed underneath the earth's surface at a depth greater than or equal to 10 m (32.8 ft).	TST
A016	3.2.3.4	Steering of Receive Antenna	The receive antenna shall be steerable in azimuth in all directions to optimize signal gain and maximize directivity.	TST
A017	3.2.3.5	Horizontal Polarization of Receive Antenna	The receive antenna shall be only horizontally polarized.	TST
A018	3.2.3.6	Receive Antenna Feeder Line	The receive antenna feeder line for each antenna shall nominally be 73 Ohms.	TST
A019	3.2.3.7	Receive Antenna Gain	The receive antenna gain shall be nominally 2.14 dBi.	TST

**Table 3.4-3 EGAS System Requirements**

### EGAS Requirements List Continued

A020	3.2.3.8	Receive Antenna Feeder Loss	The receiving feeder system loss shall be limited to least 1 dB.	TST
A021	3.2.3.9	Receive Antenna Clearance	The receive antenna shall have a clearance distance of ~1 to 3 km (~3000 to 9000 ft).	TST
A022	3.2.3.1	ELF Transmitter Power	The ELF transmitter output power shall not exceed 5 kW	TST
A023	3.2.3.2	ELF Transmitter Antenna Steering Capability	The ELF transmitter shall steer the transmit antenna 360 degrees in azimuth.	TST
A024	3.2.3.3	ELF Transmitter Tunable Frequencies	The ELF transmitter shall be tunable to 215 Hz, 220 Hz, and 225 Hz.	TST
A025	3.2.3.4	Placement of ELF Transmitter	The ELF transmitter shall be positioned ~1m (3 ft) underneath the transmit antenna to minimize insertion loss	TST
A026	3.2.3.5	ELF Transmitter Weight	The ELF transmitter shall not exceed 500 lbs.	TST
A027	3.2.3.6	ELF Transmitter Operating Conditions	The ELF transmitter shall operate between -10 deg C to +30 degrees C.	TST
A028	3.2.5.1	EGAS Signal-to-Noise (S/N) Ratio	EGAS received signal-to-noise (S/N) ratio shall not be less than 74 dB.	TST
A029	3.2.5.2	ELF Receiver Power	The ELF receiver power shall not exceed 50 W.	TST
A030	3.2.5.3	ELF Receiver Antenna Steering Capability	The ELF receiver shall steer the receive antenna 360 degrees in azimuth.	TST
A031	3.2.5.4	ELF Receiver Tunable Frequencies	The ELF receiver shall be tunable to 215 Hz, 220 Hz, and 225 Hz.	TST
A032	3.2.5.5	ELF Receiver Minimum Signal Detection	The ELF receiver input power for minimum signal detection shall be shall not exceed -120 dBm.	TST
A033	3.2.5.6	Placement of ELF Receiver	The ELF receiver shall be positioned ~1m ( 3 ft) underneath the transmit antenna to minimize insertion loss.	TST
A034	3.2.5.7	ELF Receiver Weight	The ELF receiver shall not exceed 500 lbs.	TST
A035	3.2.5.8	ELF Receiver Operating Conditions	The ELF receiver shall operate between -10 deg.C to +30 degrees C.	TST
A036	3.3.1	EGAS Failure/Fault Detection	The EGAS shall indicate failures within 20 minutes after start-up.	TST
A037	3.3.2	EGAS Failure Reporting	When EGAS determines a failure, the EGAS shall report failures via a control display.	TST
A038	3.3.3	EGAS Mean-Time Between Failure (MTBF)	EGAS Mean-Time Between Failure shall 3000 hours under continuous operating conditions.	TST
A039	3.4.1	EGAS Electromagnetic Compatibility	The EGAS shall be electromagnetically self-compatible and meet the federal guidelines.	TST

**Table 3.4-3 EGAS System Requirements Cont'd**

### 3.5 Engineering Development Life Cycle

Raytheon's Integrated Product Development System (IPDS) provides framework for incremental system and multiple product development and integration and establishes engineering automation and data management tools. This process consists of seven engineering development stages (See Figure 3.5-1). The EGAS prototype is a proof of concept design effort, which limits the engineering development cycle to stages 1 through 4.

- a. Business Strategy Execution – Stage 1 of IPDS involves EGAS project capture, proposal planning, and win strategy development for EGAS conceptual design. These activities are used in the development of a proposal package for submission to potential customers. After winning the proposal and contract award, the development process is transitioned to Stage 2 (Project Planning, Management, and Control).
  
- b. Project Planning, Management, and Control – Stage 2 entails EGAS project start-up, and initial and detailed planning. Several key activities are accomplished during this stage. These activities are the preparation of an Integrated Master Plan (IMP), Integrated Master Schedule (IMS), Risk Assessment, and an Integrated Product (IPT) structure. The Statement of Work (SOW) and Work Breakdown Structure are reflected in the IMP.

1. Integrated Master Plan:

The Integrated Master Plan (IMP) is an event-based plan to manage EGAS program activities, captures the complete set of events, significant accomplishments, test criteria, and supporting products for each Integrated Product Team (IPT) to satisfy programmatic and technical requirements (See figure 3.5-1 EGAS Integrated Master Plan). The EGAS is a two-way subsurface extremely low frequency (ELF) communication developed to provide early warning of potential threats to national security. The development of the EGAS IMP involves a well-structured iterative activity, which fully interacts with all assigned IPTs utilizing IPDS.

ID	IMP #	Task Name	IPT	Duration	mber			January		
					9	16	23	30	6	13
1		Extremely Low Frequency Global Alert System (EGAS)		1 day						
2		Integrated Master Schedule (IMS)		1 day						
3		By Julian Parker		1 day						
4										
5	✓ A-IBR-010-005	<b>(GATES 1-4) Business Strategy Execution completed</b>	PM	16 days						
8	✓ A-IBR-010-005C	<b>Contract Award</b>	PM	30 days						
9	✓ A-IBR-010-008	<b>(GATE 5) Start-up Review</b>	PM	40 days						
10	✓ A-IBR-010-009	<b>Baseline Review Conducted</b>	PM	10 days						
11	✓ A-IBR-010-009A	Action Items completed	PM	10 days						
12	✓ A-IBR-010-010	<b>Complete Initial Program Planning</b>	PM	5 days						
20	✓ A-IBR-010-020	<b>Complete EGAS Integrated Product Development System Definition</b>		25 days						
21	✓ A-IBR-010-020A	Cost & Schedule Tracking Process Defined	PM	5 days						
22	✓ A-IBR-010-020B	Configuration Management Process Defined	EGAS	5 days						
23	✓ A-IBR-010-020C	Data Management Process Defined	EGAS	5 days						
24	✓ A-IBR-010-020D	Requirements Traceability Process Defined	EGAS	5 days						
25	✓ A-IBR-010-020E	Subcontractor Oversight Process Defined	PM	5 days						
26	✓ A-IBR-010-020F	Action Item Tracking Process Defined	PM	5 days						
27	✓ A-IBR-010-020G	Design Release Process Defined	EGAS	5 days						
28										
29	✓ B-IBR-010-030	<b>System Requirements Review (SRR)</b>		31 days						
30	✓ B-IBR-010-030A	Completed System Specification	PM	31 days						
31	✓ B-IBR-010-040	<b>Develop Safety Program Plan</b>		5 days						
32	✓ B-IBR-010-040A	Draft safety program plan	EGAS	5 days						
33	✓ B-IBR-010-050	<b>Develop Security Program Plan</b>		5 days						
34	✓ B-IBR-010-050A	Draft security plan	PM	5 days						
35	✓ B-IBR-010-060	<b>Develop Initial Risk Mitigation Plan</b>		5 days						
36	✓ B-IBR-010-060A	Draft Initial Risk Mitigation Plan	EGAS	5 days						
37										
38	C-SDR-020-009	<b>System Design Review (SDR)</b>		297 days						
39	✓ C-SDR-020-009B	<b>Conduct Design Review</b>	EGAS	151 days						
40	✓ C-SDR-020-009A	Provide Design Review Package	EGAS	151 days						
41	C-SDR-020-010	<b>Perform Cost as Independent Variable (CAIV) Trade Studies</b>		95 days						
42	✓ C-SDR-020-010A	Initial Trade Studies Conducted	EGAS	14 days						
43	☒ C-SDR-020-010B	Initial Trade Studies Compiled and Documented	EGAS	5 days						
44	✓ C-SDR-020-020	<b>Initiate Definition of EGAS Interface Control</b>		30 days						
45	✓ C-SDR-020-020A	EGAS Interface Definitions	EGAS	30 days						
46	C-SDR-020-021	<b>System Concept Review (SCR)</b>		3 days						
47	C-SDR-020-021A	Hold SCR	EGAS	3 days						

**Figure 3.5-1 EGAS Integrated Master Plan**

## 2. Risk Assessment

- The potential risks of the EGAS engineering development effort are directed to the excavation, and the burial of EGAS components. The risk areas that may have impact are the confidence of site survey, personal property access for excavation, and accurate underground utility information. All of these risks have been categorized as medium to low.

- During the site survey selection, there may be contaminants found in the soil, which may impact excavation or the EGAS performance. There will be an alternate site designated as a contingency plan.
- During the excavation phase, there is a potential risk of digging in areas for which, the contractor may not have legal access to dig. To minimize this risk, the contractor will obtain a utility “Right Away” agreement, which gives the contractor legal right to dig on personal property.
- There is a potential risk during digging. There is a remote possibility that an unmarked utility line, gas pipe, and water lines may get cut or ruptured. An incident of this magnitude, would require the contractor to repair the lines and clean-up at their own expense. During the site survey and excavation, the most current ground utility map shall be used.

### 3. Integrated Master Schedule

The Integrated Master Schedule (IMS) is EGAS prototype life cycle development schedule, which was developed from the IMP. The schedule depicts the timelines, milestones, deliverables (Master’s Report), and the EGAS Concept Design Review (See figure 3.5-2 EGAS Integrated Master Schedule). Starting with the Business Capture event on December 15, 2001, with EGAS Prototype Concept Review Delivery on Oct 12, 2002.

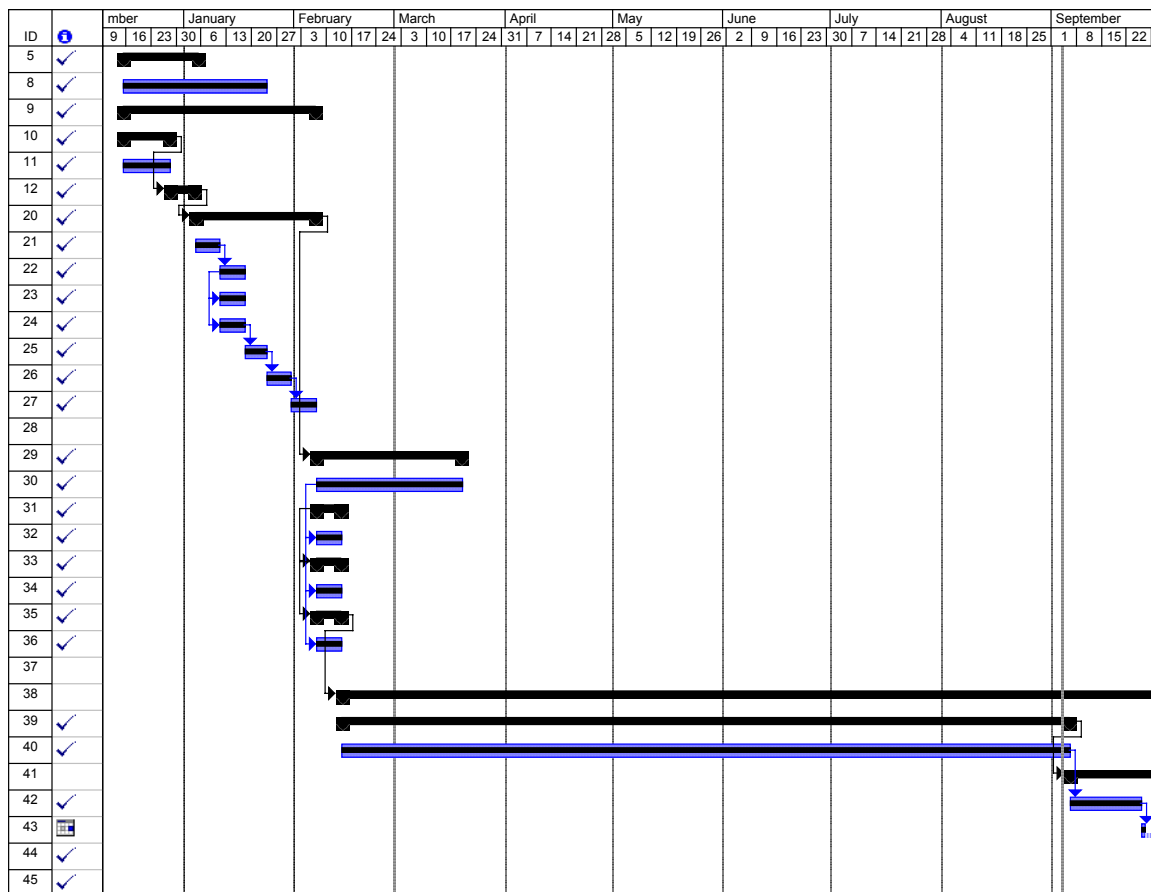

**Figure 3.5-2 EGAS Integrated Master Schedule**

#### 4. Integrated Product Teams (IPTs)

The IPTs responsible for execution of the IMP are: Program Management, EGAS (System Engineering), Transmitter, Receiver, and Antenna. (Figure 3.5-3 IPT Chart) Integration and Test (I&T) IPT and Speciality Engineering IPT are embedded in the EGAS IPT.

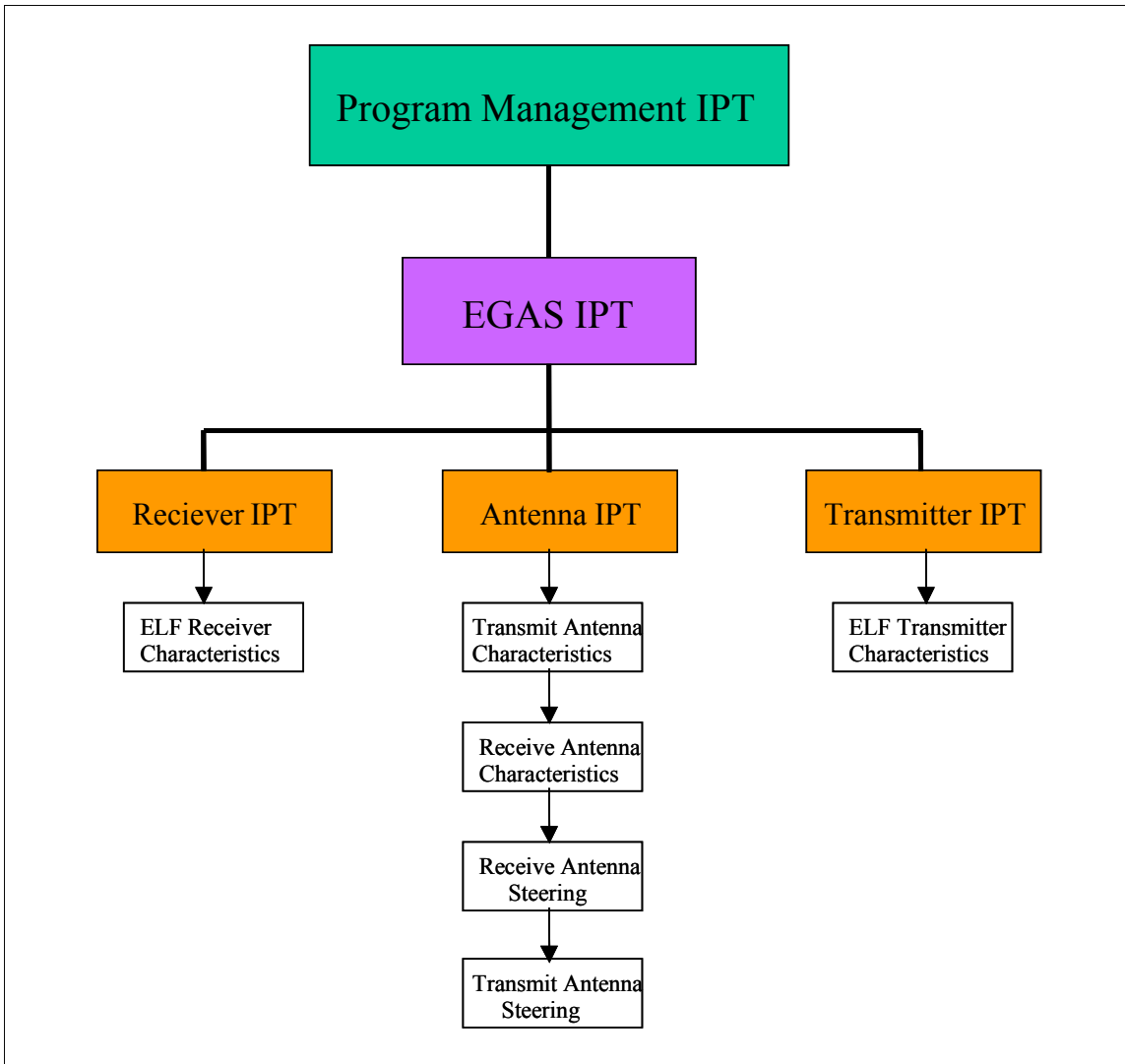

**Figure 3.5-3 IPT Structure**

After completion of these activities, the development process transitions to Stage 3 (Requirements and Architectural Development).

- c. Requirements and Architectural Development – Stage 3 Reviews the customer requirements and develops the EGAS system requirements specification (SRS). Once the SRS receives customer approval, the SRS becomes EGAS system



baseline or a preliminary design that can be used towards the development of a functional and physical architecture by allocating requirements to product and component levels.

- d. Product Design and Development - Stage 4 concentrates on EGAS products and detailed designs to support system performance requirements. Trade studies and prototyping are used to substantiate design decisions. The EGAS Prototype Review will be held to validate the concept of two-way ELF subsurface wave propagation. This review shall be an oral presentation to show a proof of concept to validate the conceptual application of ELF subsurface communication. A Masters Report o will also be provided to customer. Once the customer has approved or accepted the EGAS prototype design, the next stage of this system engineering process to develop a preliminary design and continue complete the remaining three stages of the IPDS process.

Once a preliminary product design has been established, a Preliminary Design Review (PDR) is held for customer approval. This review will provide an EGAS detailed design approach of the system and product design, which includes its physical and functional, interfaces and risk mitigation. After the customer has approved the detailed design, a Critical Design Review (CDR) is held for customer approval. This review finalizes the detail design of the system and product design, the physical and functional interfaces, and ensures that design effort is operating within cost and schedule. After completion of CDR, the

development process transitions to Stage 5 (System Integration, Verification, and Validation).

- e. System Integration, Verification, and Validation – Stage 5 begins system integration of the subsystems and components, test builds, test procedure development, and verification and validation of the system and product designs, including certifications and audits (FCA/PCA). Test Readiness Reviews (TRRs) will be held for each test build, component/module design, product (subsystem) design, and the top-level system design. Product (Subsystem) and component verification will be conducted using the System Integration lab (SIL). System verification and validation (performance testing) will be verified. Preceding each TRR, each verified test requirement are reviewed for customer acceptance. At the end of the test program a Functional Configuration Audit (FCA) and Physical Configuration Audit (PCA) is held for customer review. The FCA reviews all verification data or test results to ensure all system and performance requirements are verified and validated. The PCA compares the released drawings on the system design to the actual hardware. After the customer approves all TRRs and FCA/PCA, the system is delivered to the customer. If the system goes to production then the development process is transitioned to Stage 6 (Production and Deployment).
  
- f. Production and Deployment – Stage 6 involves factory planning (production fabrication and assembly plans), production quality assurance, unit and

acceptance testing, and product/system delivery. After completion of the system/product deliveries, the development process is transitioned to Stage 7 (Operations and Support).

- g. Operations and Support – Stage 7 provides operations and planning, system and facility operations, warranty service and support; training, supply and publication support; and obsolescence and disposal management.

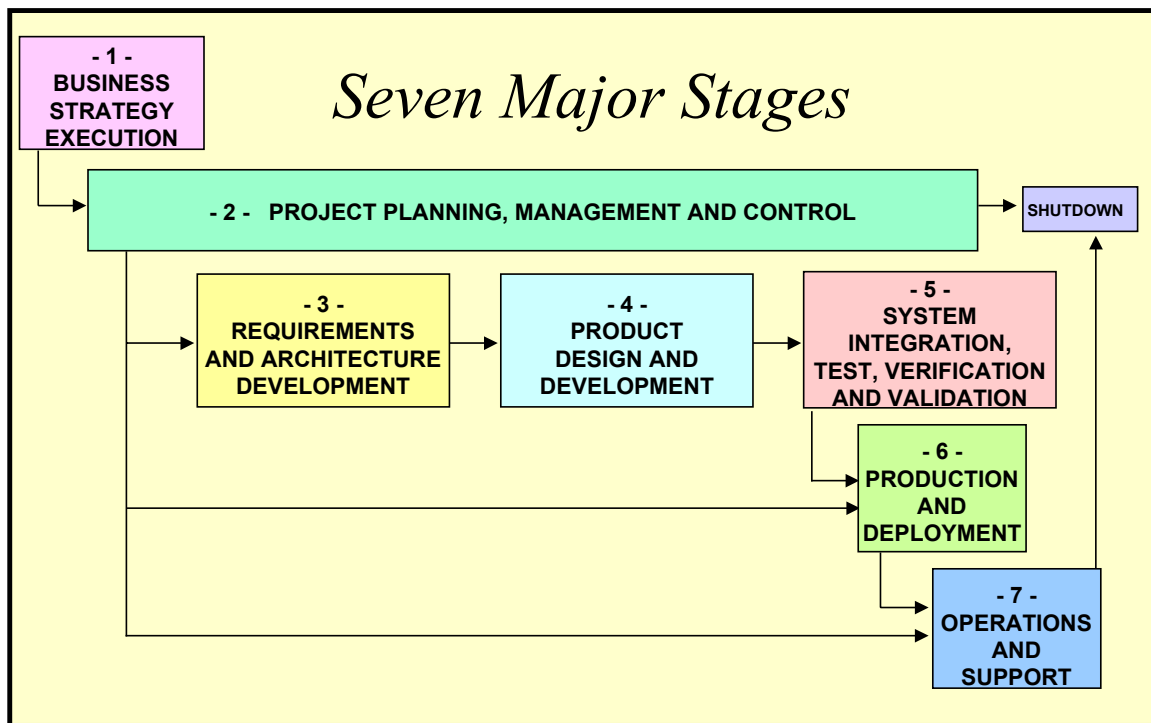

Figure 3.5-1 Raytheon's IPDS Process

## CHAPTER IV

### 4. ELF GLOBAL ALERT SYSTEM DESCRIPTION

The EGAS is a two-way subsurface communication system comprised of an ELF Transmitter System, an ELF Receiver System, a Transmit Infinitesimal orthogonal Dipole (turnstile) Antenna, a Receive Infinitesimal Orthogonal Dipole (turnstile) Antenna, and an EGAS Control System (See Figure 4.0-1). The EGAS operating frequency range shall be between 215 Hz to 225 Hz with a 10 Hz information bandwidth. The ELF system shall transmit and receive binary coded messages, repeating the message for several minutes. The transmit antenna and receive antennas shall be steerable 360° in azimuth. The EGAS transmit and receive antennas shall have a range of 5000 km (3106.9 miles). The transmit/receive antennas, ELF receiver, and the ELF transmitter shall be buried several meters beneath the surface of the earth. ELF transmit/receive transmissions will be propagated in the earth's crust. The earth's crust is the thin, rocky, outer surface of the earth, which is rich in the elements oxygen and silicon. The earth's outer surface is comprised of two types of crust, which are Oceanic and Continental (See Figure 4.0-2 layers of the Earth). Oceanic crust is primarily comprised dense rock called basaltic rock (pyroxene and feldspar). Continental crust is made of lower density rocks, such as andesite and granite.

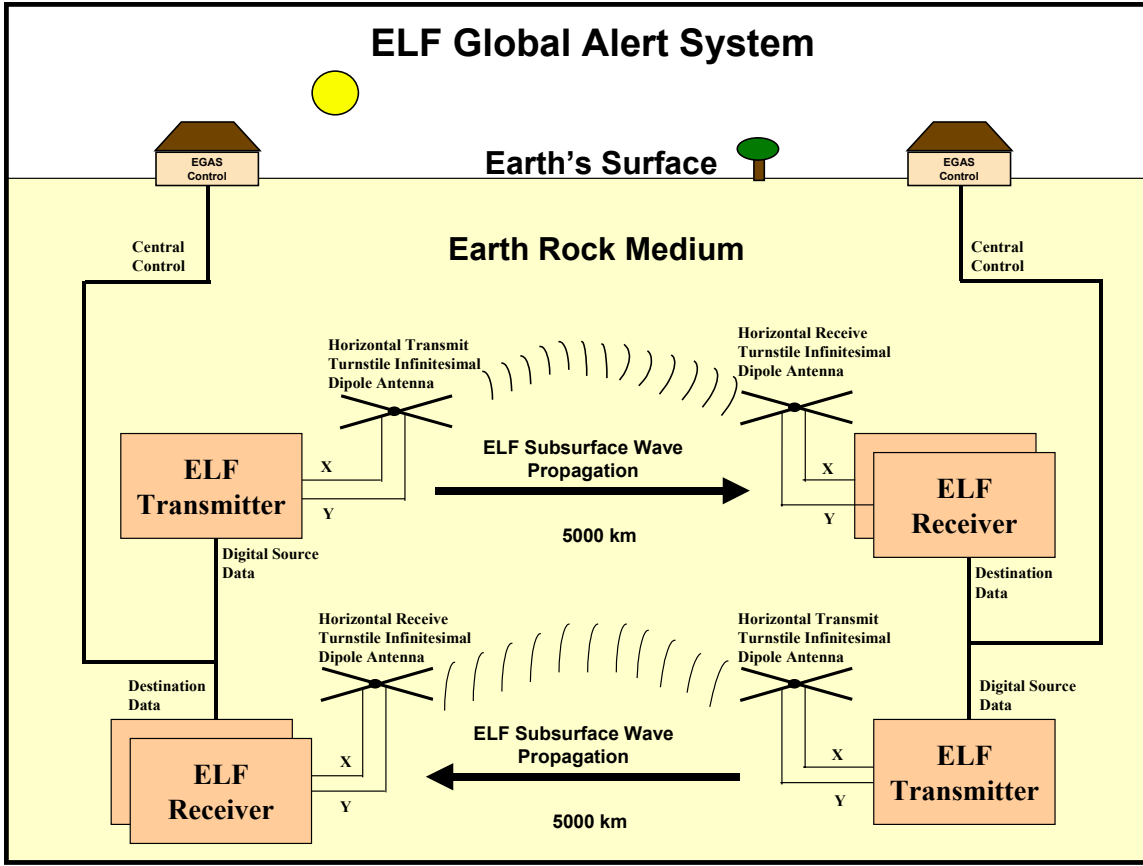

Figure 4.0-1 ELF Global Alert System (EGAS)

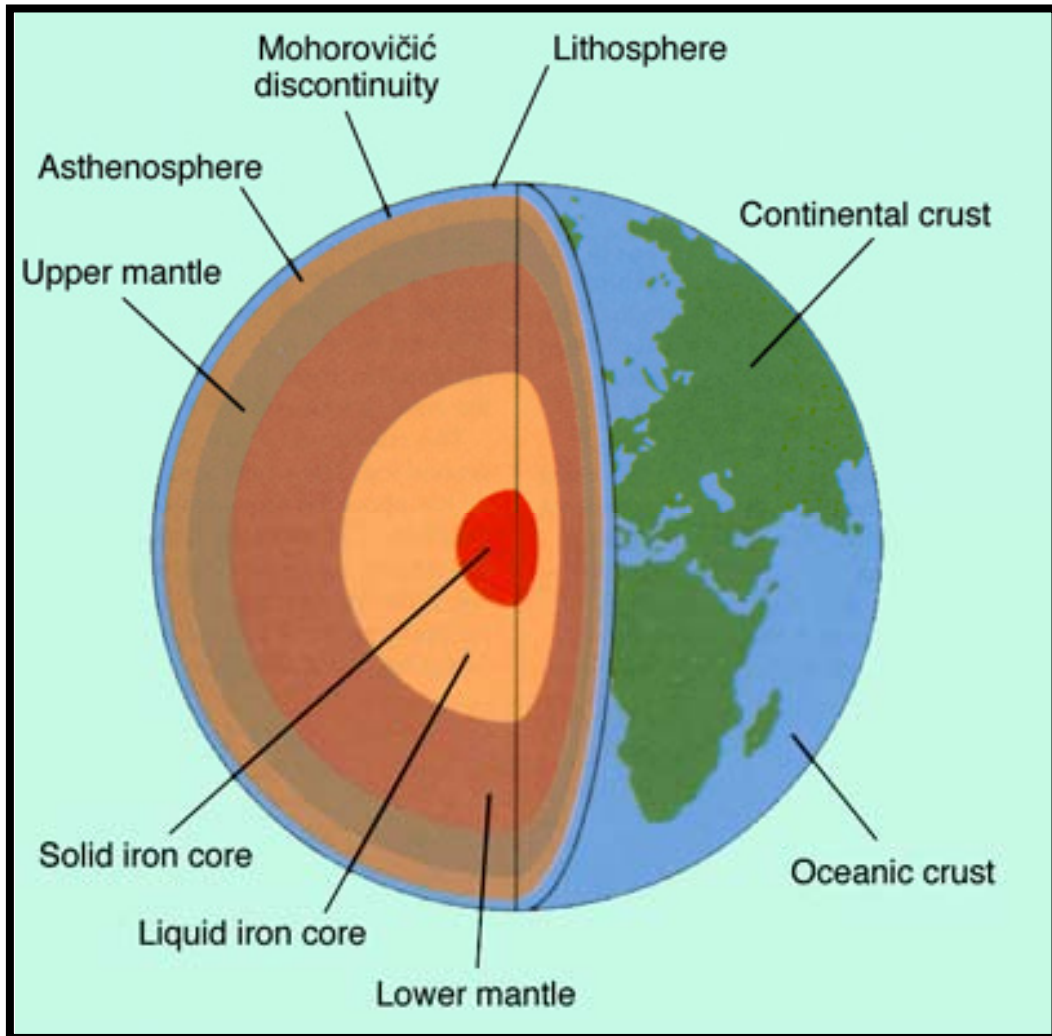

Figure 4.0-2 Layers of the Earth

#### 4.1 ELF Transmitter System

The ELF transmitter system is a high output current apparatus that operates close to zero output impedance. The EGAS operating frequency shall be tunable to 215 Hz, 220 Hz, and 225 Hz. The ELF transmitter output power shall not exceed 10 kW. The ELF transmitter shall be able to operate at temperatures between  $-10^{\circ}\text{C}$  to  $+30^{\circ}\text{C}$ . The transmitter system consists of a GPS -referenced carrier oscillator, Phase Shift Keying (PSK) Modulator, Crypto Interface Port, two Low Noise Preamplifiers, and two High AC current amplifiers (See figure 4.1-1).

The ELF transmitter shall have control of directivity of transmission. The directivity shall be either a bi-directional beam pattern or omni-directional. The directional transmit application shall require the ELF transmitter to steer the transmit turnstile horizontal infinitesimal-dipole antenna  $180^{\circ}$  in azimuth in  $1^{\circ}$  increments and to adjust the azimuth beamwidth from  $90^{\circ}$  to  $180^{\circ}$ . The ELF transmitter shall steer the transmit antenna with a  $1^{\circ}$  pointing accuracy.

Transmit antenna steering requires dividing the main feedline into a carrier reference component (X) and a phase shifted carrier component (Y). The X component provides a modulated zero-phase reference to one dipole in the turnstile. The Y component provides a variable phase shifted modulated carrier signal, which allows steering of the antenna's bi-directional e-plane pattern, which is between  $0^{\circ}$  to  $180^{\circ}$  based on an initialized antenna physical orientation. Each X and Y component feedline shall have a dedicated Preamplifier and High Current Amplifier. The ELF transmitter's Digital Signal Processor

(DSP), which consists of a  $\pi/4$  (Differential Phase Shift Keying (DPSK) modulator and a carrier phase shifter, shall perform the modulation and antenna steering and azimuth coverage function for ELF propagation.

The ELF transmitter system shall be encased in a controlled environment vault (CEV) buried approximately 10 meters beneath the earth's surface. The CEV shall provide adequate cooling, AC power, and protection during EGAS transmit operations.

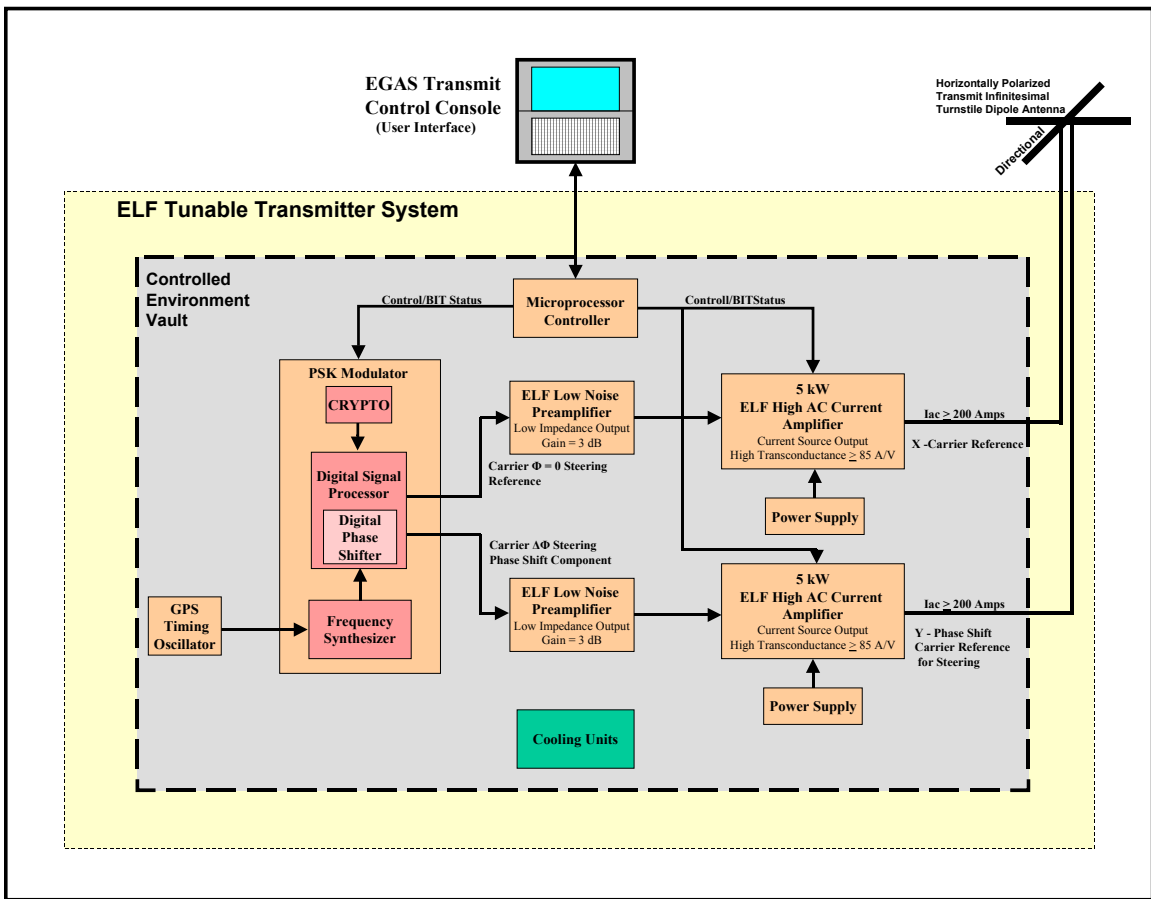

Figure 4.1-1 ELF Transmitter System



#### 4.1.1 ELF Transmitter Components

- a. GPS-referenced Oscillator - The GPS-referenced oscillator shall provide a voltage source from which a carrier frequency is generated. This oscillator shall also provide GPS frequency synchronization in order to ensure a precise carrier frequency traceable to an atomic clock standard.
  
- b. Digital Signal Processor- This DSP shall perform simultaneous PSK modulation to the carrier reference signal X and the phase shifted carrier signal Y. The DSP shall be able to change the Y carrier angle to point the antenna bi-directionally. The DSP shall also monitor the phase distortion from the transmitter to the antenna and provide adjustments if necessary to correct the phase relationship for steering and directivity.
  1. PSK Modulator - This modulator provides a constant amplitude  $\pi/4$  Differential Phase Shift Keying (DPSK), similar to frequency modulation (FM). This allows the maximum usage of system gain and limits the effects of impulse response noise. It also provides a higher data rate than simple on-off keying. The PSK modulator is part of the digital signal processor (DSP), which performs the functions of the frequency synthesizer, carrier phase shifter for antenna steering, and crypto interface device.
  2. Frequency Synthesizer – A frequency synthesizer uses the GPS-referenced oscillator output to generate fixed carrier frequencies (210 Hz to 230 Hz) at 5 Hz intervals.

3. Digital Phase Shifter - The phase shifter generates a carrier reference signal X, and a shifted carrier signal Y for antenna steering.
- c. Crypto Interface Device - This device shall provide the ability to store crypto keys/data and perform encryption on ELF data transmissions.
- d. Microprocessor Controller - The microprocessor shall be responsible for managing the other transmit module functions and communicates with the EGAS Control Console. The processor shall execute internal programs and ensures the operational reliability of the transmitter for power-up/shutdown, parameter sets, steering the transmit antenna, and built-in test (BIT) for each transmitter component or module. Monitors the frequency synthesizer circuits and the phase distortions in the transmitter components and the transmit antenna. Once the microprocessor has characterized the EGAS system, the phase error coefficients of each amplifier are fed back the DSP to ensure that each dipole in the turnstile is properly phased for steering, and with the correct modulation.
- e. Low Noise Preamplifier - The low noise preamplifier shall be used to amplify the low voltage modulated carrier from the DSP, and a provide bandwidth limiting to modulated signal. The preamplifier shall be an AC-coupled voltage-preamplifier, which features an ultra low-noise input stage, and low impedance output less 50 Ohms. It has a fixed gain of 3 dB or greater.

- f. High Alternating Current (AC) Amplifier - The high current amplifier shall be a low voltage, high AC amplifier capable of delivering a maximum antenna drive of 250 Amps and operate close to zero output impedance. The high current amplifier shall be operated with a  $\pm 250$  volt DC power supply. The amplifier shall have a transconductance gain of at least 100 dB.
- g. Controlled Environment Vault - The Controlled Environment Vault (CEV) is an environmentally controlled chamber that shall provide cooling, power, and protection for the ELF transmitter system. This vault shall be buried at depth of at least 10 meters. The CEV shall consist of at least a 20,000 BTU/HR air conditioner, a UPS backup power system (AC and DC), sump pump, and security system. The security system shall include intrusion, high water, smoke, high temperature, power failure detection, and toxic/explosive gas alarms.

#### **4.2 ELF Receiver System**

EGAS receiver shall be a dual, low-power, integrated DPSK receiver system. The EGAS receive frequency shall be tunable from 70 Hz to 3 kHz in 1 Hz steps. The EGAS receiver shall operate at temperatures between  $-10^{\circ}$  C to  $+30^{\circ}$  C. The EGAS Receiver shall consist of a GPS-referenced Oscillator, Digital Signal Processor (DSP) Control, Crypto Interface Port, Tunable Synthesizer, Microprocessor controller, and two ELF Digital Receivers (See figure 4.2-1).

The ELF receiver's demodulation functions are split in half to handle antenna steering. This portion of the receiver consists of two ELF Receiver Chipsets, two Automatic Gain Controls (AGC), two Low Noise Operational Amplifiers, two Bandpass Filter, two Harmonic Filters, and two 50/60 Hz Notch Filters.

The ELF receiver's DSP control module shall have a phase shifter embedded in its modular design, and perform the antenna steering and azimuth coverage functions for ELF receive operations. The receive directivity shall be either directional with a bi-directional beam pattern or omni-directional. The directional receive application shall require the ELF receiver to steer the receive turnstile horizontal-infinitesimal dipole-antenna 180° in azimuth in 1° increments and be able to adjust the azimuth beamwidth from 90° to 180°.

Steering the receive antenna requires the use of a divided feed line to the receive turnstile antenna. One feed line, which connected to one of the infinitesimal dipoles, provides a carrier reference component (X), while the other infinitesimal dipole shall have its signal delayed by a phase shift component (Y). The vector combination of these 2 components provides bi-directional steering and variable azimuth coverage between 0° to 180° based on an initial antenna physical orientation. The ELF receiver shall steer the receive antenna with a 1° pointing accuracy. Each X and Y component feedlines shall have a dedicated receiver system prior to signal processing.

The ELF receiver system shall be encased in a controlled environment vault (CEV) buried approximately 10 meters beneath the earth's surface. The CEV shall provide adequate cooling, power, and protection during EGAS receive operations.

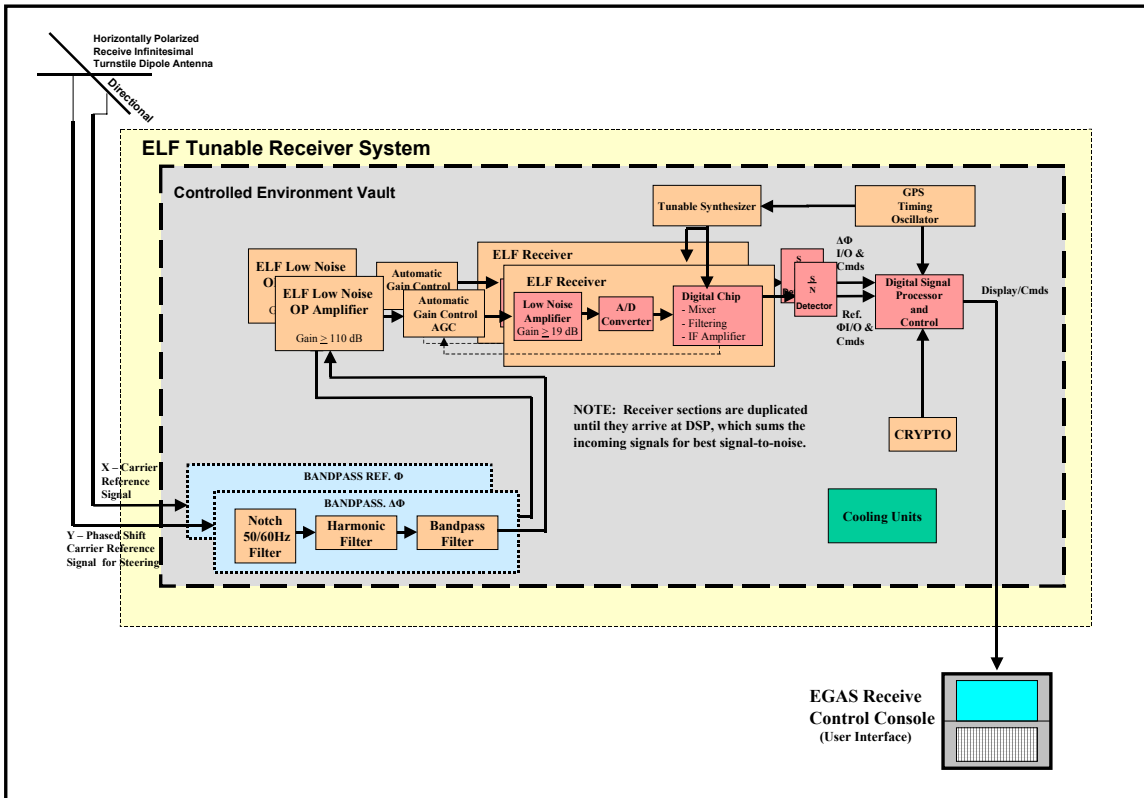

Figure 4.2-1 ELF Receiver System

#### 4.2.1. The ELF Receiver Subsystem Description

- a. GPS-referenced Oscillator – The GPS-referenced oscillator shall provide a voltage source from which a carrier frequency is generated. This oscillator shall also provide GPS frequency synchronization, which ensures a precise carrier frequency traceable to an atomic clock standard.

- b. Digital Signal Processor (DSP) Control – The DSP Control shall perform the real-time signal processing, which includes filtering, correlation, and FFT processing. The DSP’s microprocessor controller shall manage “receive” module functions and communicate with the EGAS Control System. The processor shall execute internal programs to ensure operational reliability for power-up/shutdown, parameter sets, steering the receive antenna, and built-in test (BIT) for each receiver component/module.
  
- c. Crypto Interface Port - This device shall provide the ability to store crypto keys/data and perform de-encryption on ELF data transmissions.
  
- d. Tunable Synthesizer – A frequency synthesizer shall provide fixed frequencies from 70 Hz to 3 kHz at 1 Hz intervals.
  
- e. ELF Receiver Chipset - ELF Digital Chipset shall consist of a low noise amplifier (LNA), an analog-to digital converter, and an application specific integrated circuit (ASIC) chip.
  - 1. Low Noise Amplifier (LNA) - The low noise amplifier shall be used to amplify incoming signals for received ELF frequencies. The LNA shall operate using a single low voltage supply, nominally, +5 Vdc or +6 Vdc. The low noise amplifier shall have a high gain equal to or greater than 19 dB.

2. ASIC Chip - This integrated circuit shall perform the mixer and IF I/Q down converter functions. The mixer shall perform the frequency translation (down conversion) between the RF input signal and the IF output signal. The IF amplifier shall be used to amplify and limit the amplitude of the IF signal. The IF-to-baseband conversion shall be performed by generating a "real" (I) and a "complex" (Q) baseband signal to permit PSK demodulation. The baseband ELF signals are then bandlimited by anti-aliasing filters with selectable lowpass cutoff frequency.
  3. Analog-to-Digital Converter (ADC) – device or circuit that converts an ELF (analog) signal to a digital information signal.
- f. Signal-to-Noise Detector - The signal detector shall have the capability to detect incoming ELF signals with a sensitivity less than or equal to  $-120$  dBm. The received signal is then demodulated and the minimum signal to noise (S/N) shall be established, which shall be nominally 79 to 80 dB for ELF signal processing
- g. Automatic Gain Controls (AGC) - Automatic gain control is a linear amplifier that shall be used to automatically adjust receiver gain to the minimum amount necessary to ensure good detection. This helps to help eliminate noise interference.

- h. Low Noise Operational Amplifier - A low noise, high gain precision operational amplifier shall be used for the high amplification of incoming ELF signals. The operational amplifier dynamic range (gain) shall be at least 110 dB.
  
- i. Bandpass Filter - A bandpass filter shall be used to allow ELF signals within a selected range of ELF frequencies to pass, while preventing signals at unwanted frequencies from getting through. The bandpass filter shall also optimize the signal-to-noise ratio (sensitivity) of a receiver, by rejecting unwanted signals to either side of the received carrier.
  
- j. 50/60 Hz Notch Filter - A notch filter shall be used to attenuate 50/60 Hz power line fundamental frequencies and the attendant line interference generated by power distribution systems.
  
- k. Harmonic Filter - A harmonic filter shall be used to filter out the 50/60 Hz power distribution system harmonic resonance due to the 3<sup>rd</sup>, 5<sup>th</sup>, 7<sup>th</sup>, 11<sup>th</sup>, and 13<sup>th</sup> resonance frequencies. Harmonics are multiples of the 50/60 Hz fundamental frequencies resulting from distortion in electrical power distributions systems. These harmonic voltages, currents, and electromagnetic fields can interference with EGAS subsurface communications.



### **4.3 EGAS Transmit and Receive Antennas**

To propagate two-way subsurface ELF communications over a range of 5000 km's, each EGAS site shall require two separate antennas for transmit and receive. The EGAS antennas shall consist of one "transmit" infinitesimal turnstile horizontal electrical dipole antenna and one "receive" turnstile horizontal electrical dipole antenna (See figure 4.3-1 EGAS Transmit and Receive Antennas). The length of each dipole is a 50 km (31.5 miles). The ELF antennas shall be buried beneath the earth's surface at a depth greater than 10m (32.8 ft) with a least a mile separation between transmit and receive antennas.

Both ELF antennas shall be steerable in azimuth in all directions to optimize signal gain and maximize directivity. Steering these horizontal turnstile antennas requires dividing the main feedline into a carrier reference component (X) and a phase shifted carrier component (Y). The X component is the directional reference. The Y component provides a variable phase shift carrier signal, which allows bi-directional steering and variable azimuth coverage between 0° to 180° based the antenna's initial physical orientation. The steering of these antennas shall tunable in 1° increments in either direction. The ELF antenna shall also have the capability of being omni-directional.

PVC electrical conduits shall contain a wire for each transmit and receive antenna dipole elements. The PVC electrical conduits shall provide corrosion protection, and shielding against electrical conductivity and leakage into the ground.

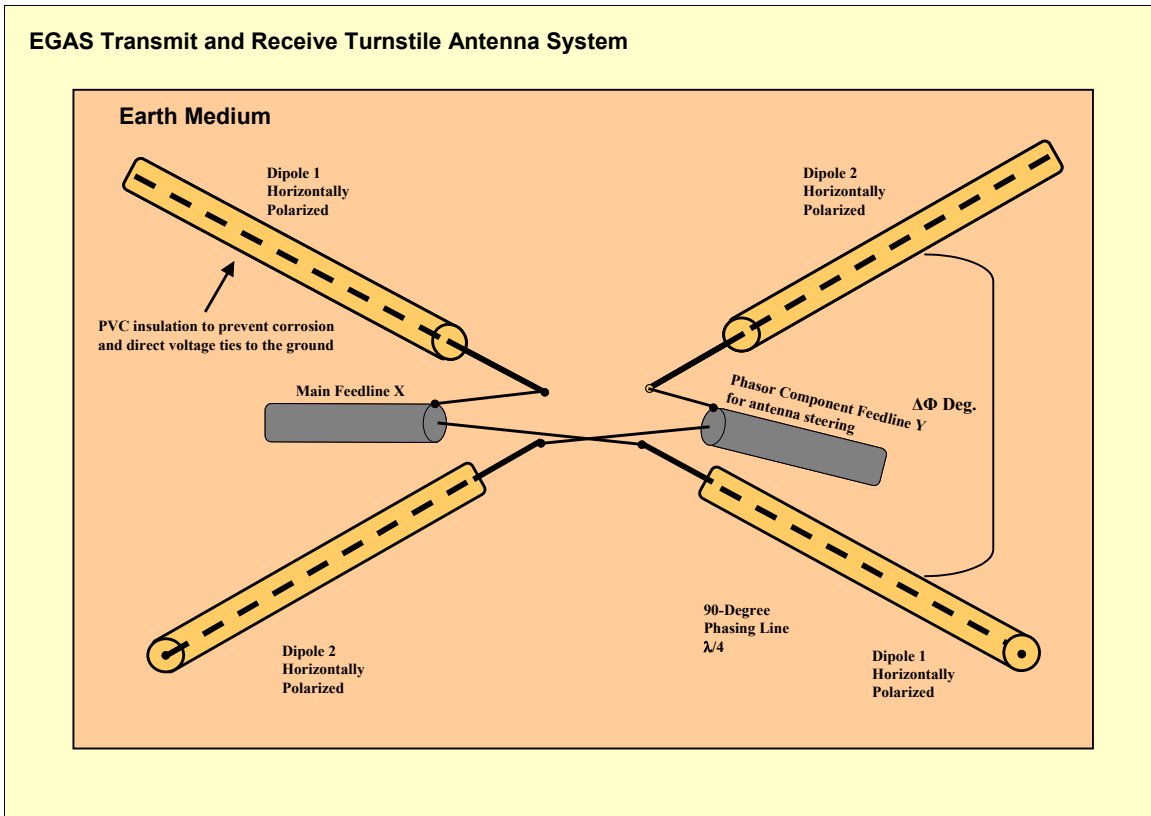

#### 4.4 EGAS Control System

The EGAS Control System shall be the user interface and central controller of the EGAS. The Control System shall be located away from the two ELF antenna sites. This control system shall consist of a transmitter control terminal, a receiver control terminal, and a Directivity/Beam Pattern Display (See Figure 4.4-1).

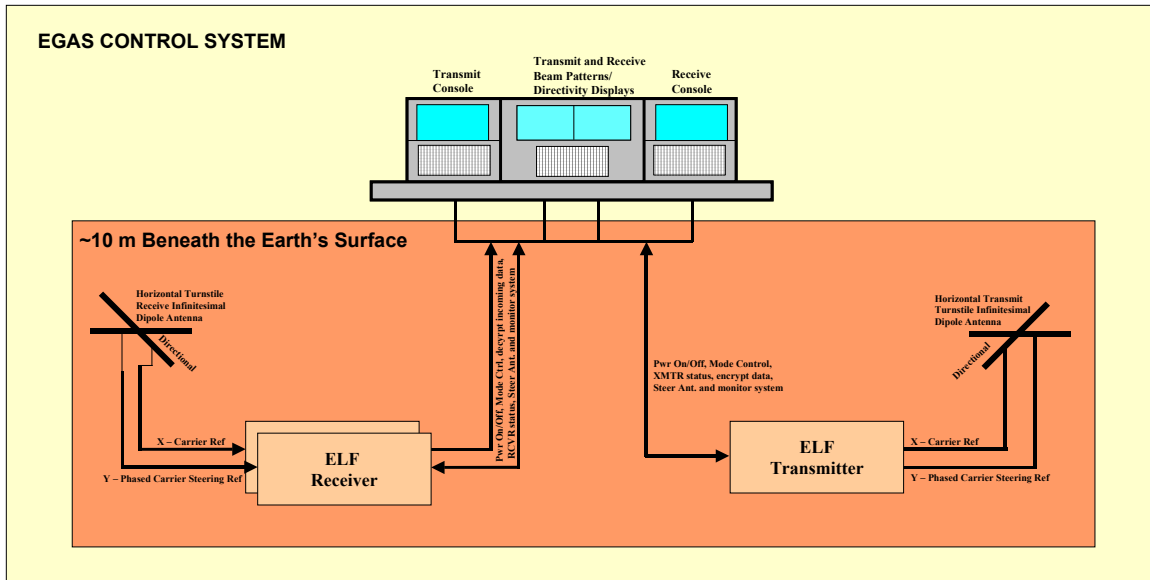
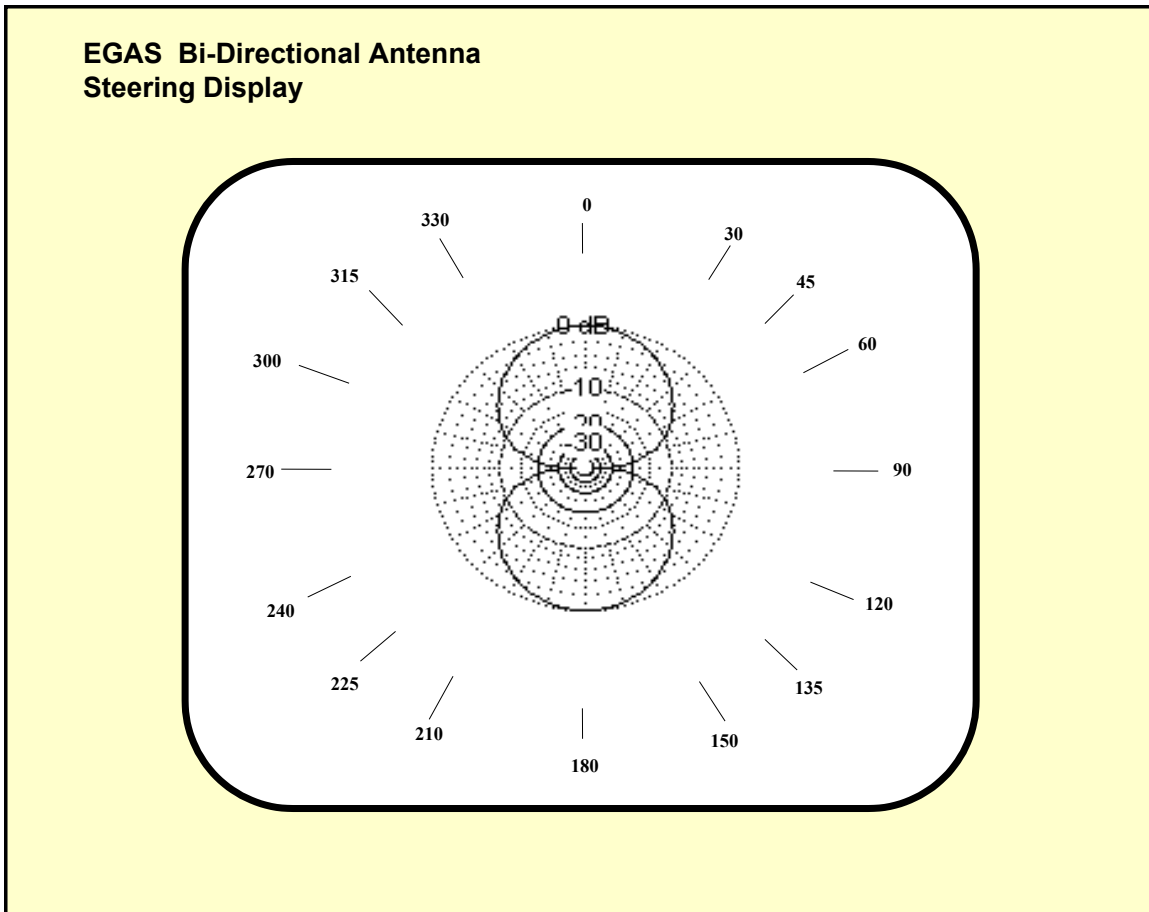

**Figure 4.4-1 EGAS Control System**

- a. Transmitter Control Console – The Transmitter Control Terminal shall provide central control to the transmitter’s power-up sequence, initial program loads, transmitter parameters, antenna program loads, and transmitter shutdown. The transmitter control console shall have the capability to steer the transmit antenna and select ELF operating frequency (215 Hz to 225 Hz). The control console shall modulate and transmit binary coded character messages and be able to initiate BIT (Built In Test) status. The terminal shall display parameter sets and program loads, coded information, BIT status, environmental status, maintenance status, operational status, alerts status, and transmit signal histograms.
  
- b. Receiver Control Console – The Receiver Control Terminal shall provide central control to the receiver’s power-up sequence, initial program loads, receiver parameters, antenna program loads, and receiver shutdown. The receiver control

console shall have the capability to steer the receive antenna, and select ELF operating frequency (215 Hz to 225 Hz). The control console shall demodulate and process received binary coded character messages and is able initiate BIT (Built In Test) status. The terminal shall display parameter sets and program loads, coded information, BIT status, environmental status, maintenance status, operational status, alerts status, and received signal histograms.

- c. Directivity/Beam Pattern Display – The Directivity/Beam Pattern Display shall display the orientation in degrees of both transmit and receive azimuth (horizontal) bi-directional antenna patterns or omni-directional patterns, if that parameter set is selected (See figure 4.4-2 Tunable Bi-Directional Steering Display).



**Figure 4.4-2 Tunable Bi-Directional Steering Display**

#### **4.5 EGAS Design Features**

The EGAS has unique design features and applications compared to traditional ELF communication systems. The traditional ELF communication systems are very large in size, high power, built above ground, omni-directional, transmits and receives in free space, and the antenna arrays are mounted above ground. The EGAS shall have the following design features, which are compact in size, low power, entire system buried beneath the surface to include the antennas, subsurface wave propagation, and it's directional.

- a. Compact - The transmitter and receiver components shall be relatively small and weight under 500 lbs per component.
- b. Low Power - The system shall be ultra low power.
- c. Buried System - The entire system, to include the transmit and receive antennas, shall be buried beneath the surface.
- d. Directional - The transmit antenna and receive antenna shall be steerable  $360^{\circ}$  in azimuth. The directivity coverage is variable from  $0^{\circ}$  to  $180^{\circ}$  (bi-directional).
- e. Subsurface Wave Propagation - This system shall conduct two-way ELF communication beneath and through the earth's surface.

#### **4.6 EGAS Engineering Development**

The development and implementation of the EGAS will be conducted in 3 Phases, which are the Development Phase, Site Survey/Excavation phase and the Integration and Test (I&T) Phase.

- a. Development Phase - The development phase concentrates on development of product and modular design. All hardware and software design documents, interface control documents, and quality assurance plans are to be successfully completed by preliminary design reviews and critical design review.

- b. Site Survey/Excavation Phase – This phase selects the location for the EGAS. The site location must meet the Environmental Protection Agency (EPA) requirements to excavate and bury the transmit/receive antennas and transmitter and receiver systems. The EGAS location has to also meet the Occupational Safety & Health Administration (OSHA) standards to bury the ELF transmit/receive antennas 10m (32.8 ft) or more below the surface.
  
- c. Integration and Test (I&T) Phase – This phase integrates the EGAS products/component designs to form the EGAS system architecture. And test EGAS system performance against the customer approved system requirements.

#### **4.7 Development Costs**

The cost for the development and verification of this ELF system will utilize a 3 phased development plan. The 3 phases are the development phase, site survey/excavation phase, and the integration and test (I&T) phase. The development phase represents the development cost of the EGAS components and associated software. The estimated cost of the site survey/excavation phase and the I&T phase will be contracted to a general contractor and/or system integrators.

- a. Development Costs - The estimated total cost of the EGAS hardware/ software and the antenna components is approximately \$11,281,250.
  
- b. Site Survey/Excavation Plan Costs – The estimated time to complete the site survey, excavation, and the burial of the ELF transmitter, ELF receiver, and the

transmit/receive antennas will not exceed 180 days. The estimated cost to complete the site survey, excavation, and the burial of the ELF transmitter, ELF receiver, and the transmit/receive antennas is approximately \$2,550,000.

- c. Integration and Test Plan Costs - The estimated time to conduct system integration and test evaluation of EGAS is approximately 15 weeks. The estimated cost to conduct system integration and test evaluation of EGAS is approximately \$1,500,000.



## CHAPTER VI

### 5. CONCLUSION

As the result of the terrorists acts conducted on 11 Sep 01, the Office of Homeland Security has asked industry to develop a secure, survivable global system to communicate with key military elements and national systems in order to provide early warnings and threat status to combat fight terrorism. In response to these initiatives, the development of an extremely low frequency (ELF) subsurface communication system prototype known as the Extreme Low Frequency Global Alert System (EGAS) was proposed. The purpose of this design effort is showing a proof of concept of ELF two-way subsurface communication within a six-month time frame. The use of the ELF spectrum was selected due its the long range propagation properties. ELF radio waves penetrate deeply beneath and through the earth's crust and interact with the geologic structure of the earth. The ELF waves propagate and its interaction with earth materials allows these waves to be used for sub-surface communications. ELF transmissions are very slow, due to its narrow bandwidth, which affect the data rate of information. Slow Continuous Wave (Morse Code) or binary character messages basically all that is practical. This type of communication does not require encryption and won't be susceptible to electromagnetic pulse (EMP) or atomic destruction.

There has also been a lot controversy on the effects of ELF Radiation and its impact on the ecological and biological environment. There have been some suggest that ELF fields may have detrimental health effects on humans if exposed for long periods of time. The claims vary from increased risk of cancer to premature births and miscarriages.

However, no conclusive proof has yet to be obtained that ELF fields are harmful to people and the environment.

The EGAS is a two-way subsurface communication system comprised of an EGAS transmitter system, an EGAS receiver system, a transmit infinitesimal orthogonal dipole (turnstile) antenna, receive infinitesimal orthogonal dipoles (turnstile) antenna, and an EGAS control console (See Figure 4.0-1). The EGAS operating frequency range shall be between 215 Hz to 225 Hz with a 10 Hz information bandwidth. The ELF system shall transmit and receive binary coded messages, repeating the message for several minutes. The transmit antenna and receive antennas shall be steerable 360° in azimuth and buried beneath the earth's surface. The EGAS transmit and receive at shall have a range of 5000 km (3106.9 miles). The transmit/receive antennas, ELF receiver, and the ELF transmitter shall be buried several meters beneath the surface of the earth.

The overall intent is to strategically position a number of EGAS within a worldwide grid to provide 360° worldwide coverage. These ELF systems will transmit and receive binary coded information, which will contain current events, nuclear and chemical threats, early warning indicators, and threat control status for US strategic forces and government agencies. This information could be used to react expeditiously and in real-time against potential threats, terrorist acts, and domestic and international incidents.

The development of the EGAS system requirements utilizes a three-phase design approach. The initial approach identified the signal processing and propagation

characteristics to effectively conduct two-way ELF subsurface communication. The second approach identified the design constraints and assumptions of propagating ELF waves through the earth's crust. This second approach served as a decision point in the determination of EGAS operating frequency selection and its architectural design. The third phase established the EGAS system and performance requirements, conceptual architectural baseline configuration and an EGAS Concept Design Review. This review is a formal presentation to show a proof of concept to validate the conceptual application of ELF subsurface communication. A Masters Report will also be submitted to the customer. Once the customer has approves or accepts the EGAS prototype design, the next stage of this system engineering process to develop a preliminary EGAS engineering development model (EDM) and continue complete the remaining three stages of the IPDS process. This system will be a valuable asset to national security, the nation's defense and terrorism.

## **6. ACRONYMS**

AC - Alternating Current

ADC - Analog-to-Digital Converter

AGC - Automatic Gain Control

ANA - Analysis

ASIC - Application Specific Integrated Circuit

BIT - Built-in Test

CDR - Critical Design Review

CEV - Controlled Environment Vault

DC - Direct Current

DEM - Demonstration

DPSK - Differential Phase Shift Keying

DSP - Digital Signal Processing

EDM - Engineering Development Model

EGAS - Extremely Low Frequency Global Alert System

E-Field - Electromagnetic Field

ELF - Extremely Low Frequency

EMF - Electric and Magnetic Fields

EMP - Electromagnetic Pulse

EPA - Environmental Protection Agency

FCA - Functional Configuration Audit

FFT - Fast Fourier Transform

GPS - Global Positioning System

GWEN - Ground Wave Emergency Network

IMP - Integrated Master Plan

IMS - Integrated Master Schedule

INS - Inspection

IPDS - Integrated Product Development Team

IPT - Integrated Product Team

I/Q - In-Phase and Quadrature

I&T - Integration and Test

LNA - Low Noise Amplifier

NTRF - Naval Radio Transmitting Facility

OSHA - Occupational Safety & Health Administration

PCA - Physical Configuration Audit

PDR - Preliminary Design Review

PSK - Phase Shift Keying

PVC - Polyvinyl Chloride

SDR - Systems Design Review

SEAFARER - Surface ELF Antenna Addressing Remotely-deployed Receivers

S/m - Siemens/meter

S/N - Signal-to-Noise

SRR - System Requirements Review

SRS - System Requirements Specification

TRR - Test Readiness Review

TST - Test

VM - Verification Method

WBS - Work Breakdown Structure

## 7. References:

An Evaluation of the US Navy's Extremely Low Frequency: chppm-  
[www.apgea.army.mil/documents/FACT/24-002.pdf](http://www.apgea.army.mil/documents/FACT/24-002.pdf)

Banister, Peter and Fraser-Smith, Anthony C., Reception of ELF Signal at Antipodal Distances: [hypertextbook.com/facts/2001/LisaWu.shtml](http://hypertextbook.com/facts/2001/LisaWu.shtml)

Bannister Peter R., Variations in Extremely Low Frequency Propagation Parameters

Burrows, Michael L., ELF Communication Antennas, Peter Peregrinus Co., 1978

Carr, Joesph J., Directional or Omni-Directional Antenna, Universal Radio Research 1999

Couch, Leon W., Digital and Analog Communication Systems, Macmillan Co, 1983

Electromagnetic Fields and Public Heath: Extreme Low Frequency (ELF)  
<http://www.who.int/inf-fs/en/fact205.html>

ELF Generation Using HAARP: <http://server500.itd.nrl.navy.mil/projects/harp/elfhrp.htm>

Evaluation of the U.S. Navy's Extremely Low Frequency Submarine communications Ecological Monitoring, National Research Council, Nat'l Res Council, National Academy Press, January 1997

Extremely Low Frequency Communication Program - United States Nuclear Forces:  
<http://www.fas.org/nuke/guide/usa/c3i/elf.html>

Extremely Low Frequency Transmitter Site Clam Lake, Wisconsin:  
[enterprise.spawar.navy.mil/spawarpublicsite/docs/fs\\_clam\\_lake\\_elf.pdf](http://enterprise.spawar.navy.mil/spawarpublicsite/docs/fs_clam_lake_elf.pdf)

FEINGOLD AMMENDMENT No. 2808 To Terminate Extremely Low Frequency Program of the US Navy: [www.fas.org/spp/starwars/congress/1998/s980625-dod-elf.htm](http://www.fas.org/spp/starwars/congress/1998/s980625-dod-elf.htm)

GWEN Ground Wave Emergency Network - United States Nuclear Forces:  
[www.fas.org/nuke/guide/usa/c3i/gwen.htm](http://www.fas.org/nuke/guide/usa/c3i/gwen.htm)

Hanyga A., Seismic Wave Propagation in the Earth, PWN-Polish Scientific Publishers-Warsama, 1985

Jones, Llanwyan and Burke, C. P., The DC Field Component of Horizontal and Vertical Electric Dipole Sources Immersed in three-layered Stratified Media, Media Physic department, Kings College, September 1996

Kelly, F.J., ELF/VLF/LF Propagation and System Design, Technical Report, NRL 9028, Naval Research Laboratories June 1987

Natural Radio and Propagation: <http://www.Iwca.org/sitepage/natrad>

Powerline (extremely Low Frequency-ELF Electromagnetic Field and Cancer –The Doll Report: [http://www.arpansa.gov.au/news/doll\\_emf.htm](http://www.arpansa.gov.au/news/doll_emf.htm)

Power Quality and Harmonics:

[http://www.energyusernews.com/Fundamentals\\_Item/00,2637,17285,00.html](http://www.energyusernews.com/Fundamentals_Item/00,2637,17285,00.html)

Powerline Harmonic Radiation (PHLR): <http://www.oulu.fi/-spaceweb/textbook/plhr.html>

Setain, Leo, Antennas with Wireless Applications, Prentice Hall HTR 1998

Steinberg Bernard D., Principles of Aperture and Array System Design, John Wiley & Sons 1976

The GWEN System: [educate-yourself.org/gwentowersbybyronweeks.html](http://educate-yourself.org/gwentowersbybyronweeks.html)

The Ground Wave Emergency Network:

[www.totse.com/en/politics/us\\_military/gwen.html](http://www.totse.com/en/politics/us_military/gwen.html)

The GWEN System: [users.shore.net/~mfoster/GWEN.htm](http://users.shore.net/~mfoster/GWEN.htm)

Understanding Harmonics:

[http://www.powerdesigners.com/InfoWeb/designer/Design\\_Tips/Harmonics/Harmonics.htm](http://www.powerdesigners.com/InfoWeb/designer/Design_Tips/Harmonics/Harmonics.htm)

Wait, James R., Electromagnetic Probing in Geophysics, Golem press 1971

White. J. E., Seismic Wave Radiation, Transmission, and Attenuation, McGraw-Hill, Inc, 1965